

Customer Support

Monday-Friday: 9: 00am-17: 00pm

[Mail: vevorkitchen18888 @outlook .com](mailto:vevorkitchen18888@outlook.com)

You can contact us when you meet any problems,

we will serve you with all our heart.

Your satisfaction is our priority!

More about Our Ice Maker



IB series ice maker Installation maintenance Manual

The manual covers the following
IB200A ,IB255A ,IB320A

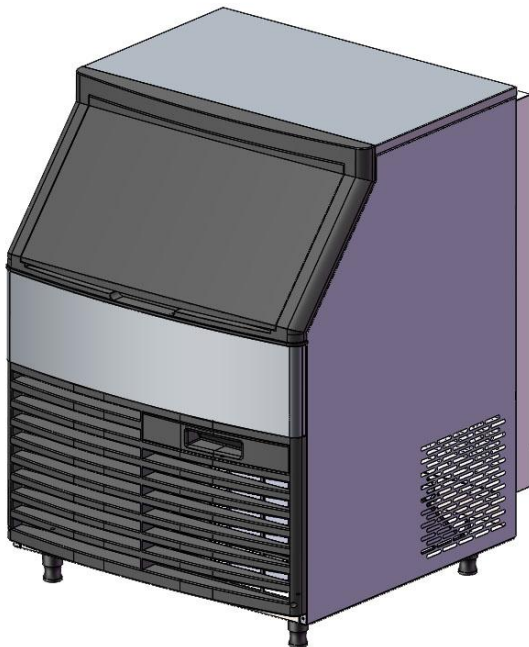

Content

1. Features -----	3
2. Appearance &Size-----	3
3. Unpack-----	4
4. Installation Location -----	4
5. Leveling Adjustment -----	4
6. Water supply/Purge -----	5
6.1 Water Supply -----	5
6.2 Drainage -----	5
7. Power supply -----	6
8. Sanitation after Installation -----	6
9. Check after Installation -----	6
10. Operation -----	7
11. Working process-----	8
12. Operation Inspection -----	8
13. Routine cleaning -----	9
13.1 Shell Dismantling-----	9
13.2 Evaporator Cleaning-----	9
13.3 water sink cleaning -----	10
13.4 Cleaning of condensers -----	10
14. Cleaning & Disinfection -----	12
14.1 Cleaning process -----	12
14.2 Disinfection process -----	14
14.3 Removal / Installation of Parts---	15
15. Out of use/Winterization -----	16
16. Maintenance -----	16
17. Circuit diagram -----	17
18. Exploded drawing -----	18

When operates and maintains an ice maker ,be sure to pay attention to the safety tips in the manual. Ignoring these tips may result in personal injury and ice maker damage.

In this manual, you will see the following forms of security tips :

Warning

Possible personal injury would be happened when not following up regulations of installation, operation or using altered equipment.

Note

The correct installation, usage and maintenance of the ice maker is very important to the output of the ice maker and reduce the failure rate. Please read and understand this manual. which contains valuable information on installation. usage and maintenance. If you encounter problems not covered in this manual, you may contact our company or our service provider at any time.

Important

The mentioned information about adjustment, maintenance and sanitation is not subject of the range of warranty clause.

Please preserve this manual well

The manual is an integral part of the product, please keep it properly. Be sure to read carefully the warnings, notices and important matters described in this manual, because these warnings, notices and important matters provide the installer/user with important information needed for proper installation, continuous and safe use and maintenance of the product. Please keep this manual for reference when necessary.

Features

1. Features

I B series of ice maker, with a number of patent control systems, simple operation, accurate control, suitable for different water quality conditions;

- Key components apply internationally well-known brands to ensure reliable work in harsh environments;
- Contact with water, use food grade plastic material, shell using stainless steel material to ensure food safety and excellent rust-proof performance.

2. Appearance & Size

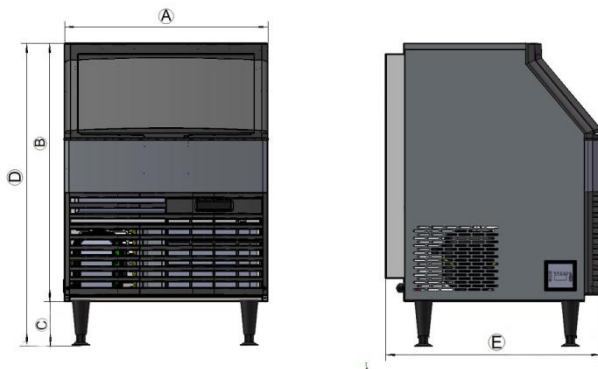

● Ice maker size list (in cm)

	A	B	C	D	E
IB200A	66.5	84.5	6.5	91	72.5
IB255A	66.5	84.5	6.5	91	72.5
IB320A	66.5	84.5	6.5	91	72.5

● Shape of Ice Machine

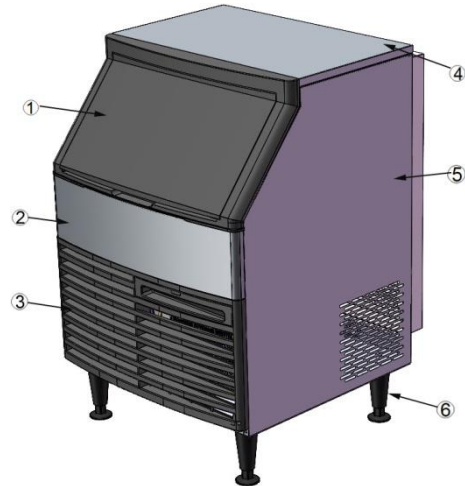

- ① ... ice maker door ② Decorative panel
 ③ Ventilation windows
 ④. Top cover plate ⑤ Right panel ⑥ Adjustable foot

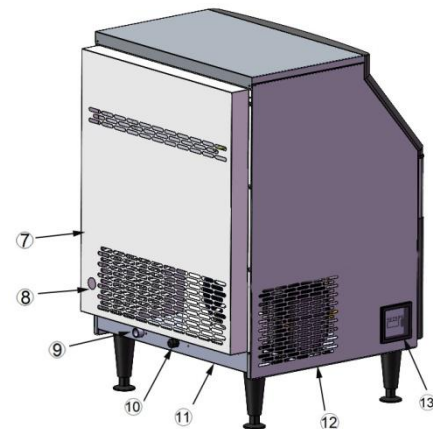

- ⑦. Back panel ⑧ Drain hole
 ⑨ Water inlet valve
 ⑩. Power cord connector 11. Bottom panel
 12. Left panel ⑬. Control screen

3. Unpack

- Before unpacking, check the anti-tilt sign is in good condition, the outer packing of the machine is in good condition, and the machine model matches your purchase.
- Take out accessories and affiliated documents, check for its consistency with packing list.
- If there is any discrepancy or damage, please contact our company/distributor directly..

4. Installation Location

- The ice maker is not suitable for outdoor usage, the installation location should not be closed to heat source or be exposed under direct sunlight.
- The normal working ambient temperature should be ranged between 10°C ~ 38°C, the water temperature should be between 5°C ~ 32°C. If the ice-making machine operates beyond the above normal temperature range for a long time, its ice-making capacity may be affected.
- Ice makers should be placed near drinkable water supply. It is recommended that distance between ice makers be less than one meter;
- Do not block the ventilation window of the ice maker. There should be enough air convection space around the ice maker;

- The ice maker can not work at sub-zero temperatures, to prevent supply line failures, empty the ice maker when the temperature is below zero(see “preparation for long-term storage of ice maker”).

5. Leveling Adjustment

- Screw the adjustable part of the four adjusting bottom feet to the end, and then rotate the adjusting bottom foot into the corresponding installation hole at the four corners of the bottom plate of the ice machine;
- Move the ice maker to the installation position. Use a horizontal ruler to adjust the level of the ice maker.

Note

Do not use the method of cushioning hard objects under the bottom foot to adjust the level of the ice maker. To ensure that the ice machine four feet stable contact with the ground, to prevent machine operation vibration.

Water supply/Purge

6. Water supply/ Drainage

Warning

Ice makers shall be installed in accordance with safety standards and shall not be installed on the aisles of public buildings.

6.1 Water supply

- Depends on local potable water quality, determining if a water treatment system is needed to prevent sediment formation, filtering out impurities and removing bleach smell .
- Please install water supply pipe according to below instruction :
 - Don't connect ice maker to hot water pipe ;
 - Water supply pressure range is 1bar ~ 5bar. Using water pressure regulator for water supply pressure over rang.
 - Individual water faucet must be installed for ice maker.

6.2 Purge

- When installing drain pipe, follow these guidelines to be sure all drained water flowing into gully drain :

- The main gully drain capacity shall be enough for all drain water:
 - Drain pipe should be wrapped with insulation material to prevent condensation.
 - The drain pipe of the water-cool condenser and the drain pipe of ice bin should be placed separately
 - About 2.5 centimeters drop needed for each one meter additional drain pipe and must not be bent

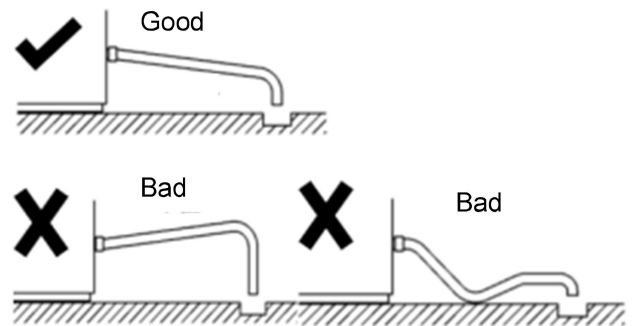

7. Power supply

- The voltage, frequency and capacity of the power supply shall be consistent with the nameplate of the machine.
- $\pm 10\%$ fluctuation of rated power voltage is allowed.
- Separate circuit breakers must be installed for the ice maker..

Warning

The power supply must be reliably grounded, and the wiring must conform to the national and regional laws and regulations of the ice maker.

8. Clean after Installation

After the ice maker is installed, clean the shell, liner and ice scoop with a clean wet cloth or sponge;

Warning

Banana oil, oxalic acid, hydrochloric acid, alcoholic liquids and other corrosive detergents are strictly prohibited.

9. Check after Installation

After the ice maker is installed, check against the following information before operation.

- Does ice maker place levelly ?
- Have you removed all the transportation seals ?
- Are all the water and electricity connected well ?
- Is the supply voltage consistent with the rated voltage on the nameplate?
- Is the ice maker properly grounded?
- Are there adequate air Spaces around the ice maker?
- Is the ambient temperature of the ice maker between 10°C and 38°C ?
- Does the water inlet temperature remain between 5°C and 32°C ?

Are the ice maker and ice bin cleaned ?

Ice Maker Operation

10. Operation

10.1 Power on/off

- Power on: connect water supply and drainage, plug in power plug, display screen is all bright;



- Power off: press "power" key, ice machine into standby state, digital tube display "OFF", and then pull out the power plug.



10.2 Ice thickness regulation

- Ice thickness adjustment: press the thick (or thin) button for 5 seconds, Before the digital display C1, The last two started flashing, Enter the ice thickness setting state. At this point, Press the thick (or thin) button every time, Digital display increases (or decreases)1, indicates an increase (or decrease) in ice-making time for 1 minute,

Adjust the range to 0~35 minutes. If you don't press the button in 10 minutes, Then the digital stops flashing, Into normal operation, The ice thickness set at the same time is saved.

10.3 Forced de-icing

- Forced deicing: in the state of ice making, press the status "key to start forced deicing.

10.4 Manual cleaning

- At any time press "cleaning" key, enter the cleaning state, only pump work, screen display start timing, about 30 minutes later, cleaning stop, protection shutdown;
- Note: if you need quick cleaning, you can not wait 30 minutes to press "cleaning" into the rinsing stage, rinsing if you do not need to cycle many times can press "power" key to stop rinsing, into standby state;

11. Working process

11.1. **Ice melting process:** the display screen is fully bright after power on and completely extinguished after 1 second. Display C00 indicates that in the water inlet state, until the water is full, it does not enter the power-on delay state, the deicing indicator lights shine, and the digital tube displays the power-on delay time. The hot valve opens, the compressor opens after 30 seconds, the hot valve closes after 5 seconds, and deicing after 60 seconds.

11.2. **Ice making process:** during ice making, the ice indicator light is on, the digital tube shows the ice making time, and if the ice skating board is opened continuously for more than 4 minutes, it will turn to the ice full state. The compressor continues to open, the heat valve closes, the fan is controlled, the upper water valve is controlled 5 minutes before the start of ice making, more than 5 minutes later, and the pump opens after 90 seconds. When the water temperature is lower than the setting temperature of ice making, start timing, when the ice making time exceeds the set time, the ice making ends.

11.3. **Deicing process:** after the ice making is finished, it enters the deicing state, the deicing indicator light is on, and the digital tube shows the deicing time. Compressor continues to open, hot valve open, pump, fan closed, upper water valve controlled. The maximum time limit for deicing is 6 minutes. If the ice is not taken off for 5 minutes, open the pump for 1 minute. If the ice is still not taken off, turn to ice making, if the ice is not closed,

turn to ice full. Three times in a row for more than 6 minutes, turn to deicing timeout stop.

11.4. **Ice full detection:** after the ice is removed, if the ice in ice bin is not full, enter the ice making state and carry out a new cycle. If the ice bin is full of ice, enter the ice full stop state, ice full indicator light. Water pump, compressor, heat valve, upper water valve, fan all closed. If the ice is removed, within 180 seconds of the press closing, the ice full indicator lights shine. If the pressure mechanism is closed for 180 seconds, turn to power up for a new cycle. If the ice is not taken away, it is always in a state of ice.

12. Operational inspections

- Make sure the tap is open.
- Make sure the inlet valve is open.
- The ice maker has been powered on.
- Check all pipes and fittings to ensure no leakage.

▲ attention

The ice maker has been tested and debugged in the factory before shipment. The new machine does not need any debugging. In order to ensure the normal operation of the ice maker, operation inspection is required under the following circumstances;

- Initial initiation
- Restart after long downtime
- After cleaning and disinfection

Check before operation

13. Routine cleaning

▲ attention

- It is strictly forbidden to wash the ice machine with water sprayer. Do not use any alcoholic liquid to clean or disinfect the ice maker, otherwise it may cause cracks in plastic parts;
- Remove the roof and back panel, and should be removed by maintenance personnel with relevant knowledge;
- Do not wash plastic parts in water or dishwasher above 40°C temperature to avoid damage to parts.

Environmental cleaning: often clean the ice maker to keep the environment clean and make the equipment run efficiently.

- Shell cleaning: clean the ice machine with sponge dipped in neutral cleaning liquid and dry with clean soft cloth. Use stainless steel cleaners if necessary.
- Air filter cleaning: filter can filter dirt or dust in the air to prevent condenser clogging. If the filter is blocked, the performance of the ice maker will decline. It is recommended that air filters be cleaned once or twice a month:

13.1 Shell Dismantling

★ important

If necessary, it is not recommended to remove the top cover plate, please have the relevant knowledge or under the guidance of professionals.

If cleaning is required, disassemble and assemble as follows:

- Remove the top cover plate of the ice maker and have a screw behind the ice maker, remove it with a cross screwdriver,

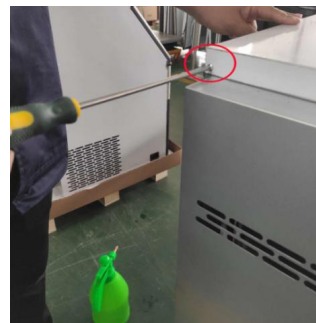

Lift up the top cover gently, then pull back gently, you can pull out the top cover

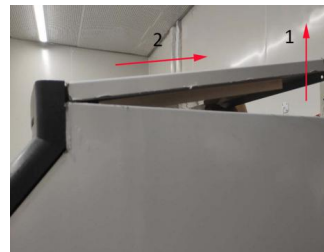

- Remove the back plate of the ice maker with a cross screwdriver to remove the upper two screws of the back plate, gently lift the back plate up, you can remove the back plate (note: drain pipe through the back plate, gently pull the back plate, place);

Cleaning and Disinfection

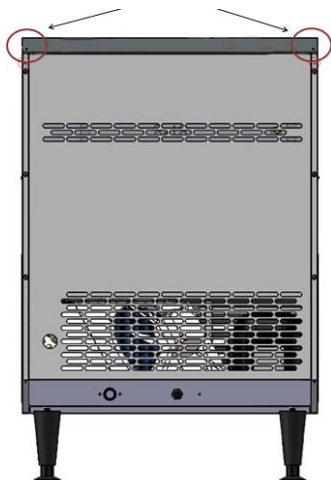

13.2. Evaporator cleaning

- Scrub the evaporator surface with a brush or sponge dipped in scale remover or vinegar;



Use nylon brush to dip in scale remover or vinegar to wash plastic parts around evaporator;

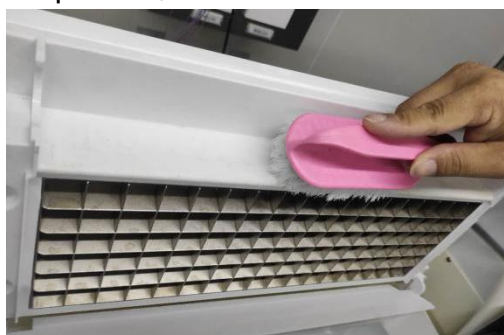

13.3 Water sink cleaning

Press [POWER] key to be in standby state, the screen shows "OFF", unplug the power plug,

remove the two screws on the pump box with a screwdriver, loosen the three screws on the inner wall of the ice storage barrel, remove the clamps, unplug the upper water pipe, pump and float plug-in to remove the pump and float clean;



Use soft ground materials such as brush or sponge to dip in scale remover or vinegar to scrub the sink.



Cleaning and Disinfection

13.4 Cleaning of condensers

Warning

Clean condenser, must disconnect ice machine power supply. Condenser edge sharp, clean carefully cut.

★ important

The dirty condenser will block the circulation of air, cause the operating temperature of the ice maker to be too high, reduce the amount of ice making and shorten the service life of the parts.

It is recommended that the condenser be cleaned every six months, following the following steps:

Use cross screws to remove the left and right sides of the ventilation window, remove the ventilation window;



11/21

Pull up the filter on the ventilation window



Use nylon brush filter to remove dust;



Brush condenser fin dust with nylon brush along the upper and lower direction;

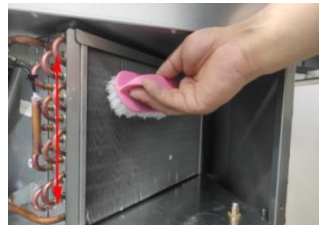

★ important

After cleaning, please install back the top cover plate, back plate, correct installation cooperation.

14. Cleaning & Disinfection

To be sure the ice maker can run stably and efficiently, the user is responsible for the operation according to the requirements of cleaning and disinfection (cleaning and disinfection operation is not covered by the warranty). If the ice maker needs clean and disinfect in short of period, please check if the water supply is appropriate, if the environment is clean, or if an inappropriate water filter is used.

Note

- **Do not mix disinfectant with cleaning agent.**
- **Do not clean evaporator surfaces with sharp objects.**
- **It is recommended to implement this process at least once in 3 months.**

Warning

- **Wear protective equipment such as rubber gloves, masks and protective glasses before cleaning and disinfection.**
- **Removal and installation of cleaned parts must be carried out in case of power failure.**

14.1 Cleaning process

1. Open the ice maker door and check that the ice maker evaporator is making ice. When ice is

being made, a forced deicing program can be performed (see "10.3 forced deicing "above) to stop the ice maker and press [power] key to be on standby ." OFF";" is displayed on the screen



2. Remove all ice from the refrigerator with an ice shovel;
3. Click "[cleaning]" key, the ice maker enters the cleaning state, only the pump works, the screen display starts timing,



When running water on the evaporator,

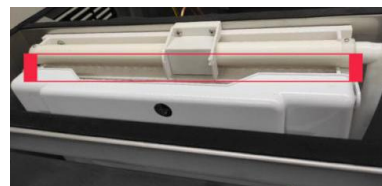

4. Add 2 packs of cleaning agent (KAY DELIMER ,56.7g/ pack) or mixed detergent to the ice maker sink



Cleaning and Disinfection

- Water between the tank and evaporator has been circulating cleaning, about 30 minutes later, the cleaning stopped, manual discharge of water in the tank;
- Press "[cleaning]" key, enter the automatic rinsing stage, the rinsing process recirculation 5 times, the whole cleaning process is over, the screen shows "OFF", into standby state, the whole process takes about 37 minutes;
- Unplug the power.
- Remove flow pipe, water retaining plate, take out water pump, float ball, ice shovel (removal method refer to parts removal / installation process).
- Mix 8 liters of warm water (45~50°C) and 4 packets of cleaning agent (KAY DELIMER ,56.7g/ package) into cleaning liquid (the amount of cleaning liquid needs to be adjusted appropriately).
- Soak the parts in the cleaning solution for more than 5 minutes (if the scale is heavy, it is recommended to soak for more than 10 minutes).



- While soaking parts, wipe the surface of parts in contact with water and ice with nylon brush or soft cloth dipping cleaning liquid, such as evaporator ice grid, ice baffle, ice storage

bucket, etc .(the dead corner can be dipped in cleaning agent wet rag wrapped disposable chopsticks cleaning). Rinse with clean water (5 times).

Scrub the ice shield



Wash the refrigerator



Brush pipe mandrel

Brush pump bottom



Plastic parts around brush steam



Brush evaporator



Cleaning and Disinfection

Brush sink



Flush evaporator



Flush hose and mandrel



12. Remove the soaked parts and rinse them with clean water (5 times).

14.2 Disinfection process

1. Mix 8 liters of warm water (45~50°C) and 2 packs of disinfectant (KAY5,28.4g/ package) into disinfectant solution (the amount of disinfectant is adjusted according to the amount of cleaning parts needed).
2. Soak the cleaned parts in the disinfectant.



While soaking the parts, spray the disinfectant evenly and completely on the surface of the parts in contact with the ice, such as evaporator ice grid, ice baffle, ice storage bucket, etc. (the dead corner can be wrapped with disinfectant wet rag wrapped in disposable chopsticks cleaning).



After 20 minutes, remove the soaked parts and rinse them with clean water. Install the removed parts back to their original position (installation method refers to 14.3 parts removal / installation process) strictly follow the requirements.

3. 1 liter of water and 1/2 package of disinfectant (KAY5,28.4g/ package) were used to form disinfectant.
4. Plug in the power plug, then press [power] key to make the ice maker in standby state, the screen shows "OFF"; press "[cleaning]" key, the ice maker enters the cleaning stage, only the pump works, the screen display starts timing, when the evaporator starts running water, add the equipped disinfectant to the ice maker. At the same time, the outer surface of the water spray tank with disinfectant

Cleaning and Disinfection



Water between the tank and evaporator has been circulating cleaning, about 30 minutes later, the cleaning stopped, manual discharge of water in the tank;

5. Press "[cleaning]" key again, enter automatic rinsing stage, tap water rinsing process cycle 2 times, then rinse cycle with pure water 3 times, the whole cleaning process is over, the screen shows "OFF", about 37 minutes after the whole cleaning process is over, " The screen shows OFF", in standby and unplug.
6. Note: after cleaning and disinfection, start making ice, the first 5 plates of ice discarded, do not eat.

14.3 Removal/installation process of parts

- a . When removing the pipe, remove "pull out" clamps "and" upper pipes "(as shown):

Pull out the hose



Unplug pipe



- a. Remove two screws

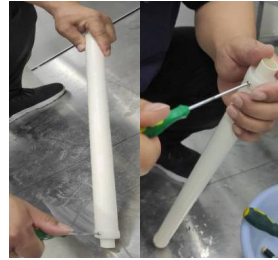

- b .

Spin out the plastic cover and remove the plastic mandrel



Note: when the pipe is assembled, the pipe hole position and mandrel hole position direction should be opposite, must not be the same direction, the correct diagram is as follows:



- c . Disassemble and assemble the baffle: grasp the middle position of the baffle and use a flat screwdriver to force from one side to the other until one side of the baffle is removed from the pin hole.

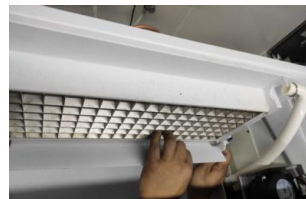

15. Out of use/Winterization

Note

If water is left in the machine in an environment below 0°C, it may cause serious damage to the machine parts. This fault is not covered by warranty..

Special protection measures are required if the ice maker is out of service for a long period of time or exposed to an environment of 0°C or less. Follow these steps below:

- Disconnect the power to the ice maker.
- Disconnect the water supply to the ice maker.
- Empty the sink.
- Remove water inlet hose and drain it from the water inlet.
- Ensure that there is no water residue in the inlet, drain and distribution pipes.

16. Maintenance

Warning

Component parts shall be replaced with like components and that servicing shall be done by factory authorized service personnel, so as to minimize the risk of possible ignition due to incorrect parts or improper service.

Before applying for repair, please consider the following aspects in order to quickly identify and improve the efficiency of machine recovery.

a). Whether the water supply is normally, including faucets open, inlet valve not blocked, and water pressure is in 1bar~5bar.

b). Whether the power supply is normal, including voltage is in $\pm 10\%$ of rated voltage, power switch is connected, the fuse is not burnt out and whether the plug is fixed well.

c). Whether the ambient temperature is too high or too low (the operating temperature range of the ice maker is 10°C ~ 38°C), whether the water temperature is too high or too low (the water temperature range is 5°C ~ 32°C).

d). Whether the ice bin is full of ice and can work after ice take away.

Write down the number of the machine and call the toll-free phone number labeled with the service label or your service provider.

Circuit diagram

17. Circuit diagram

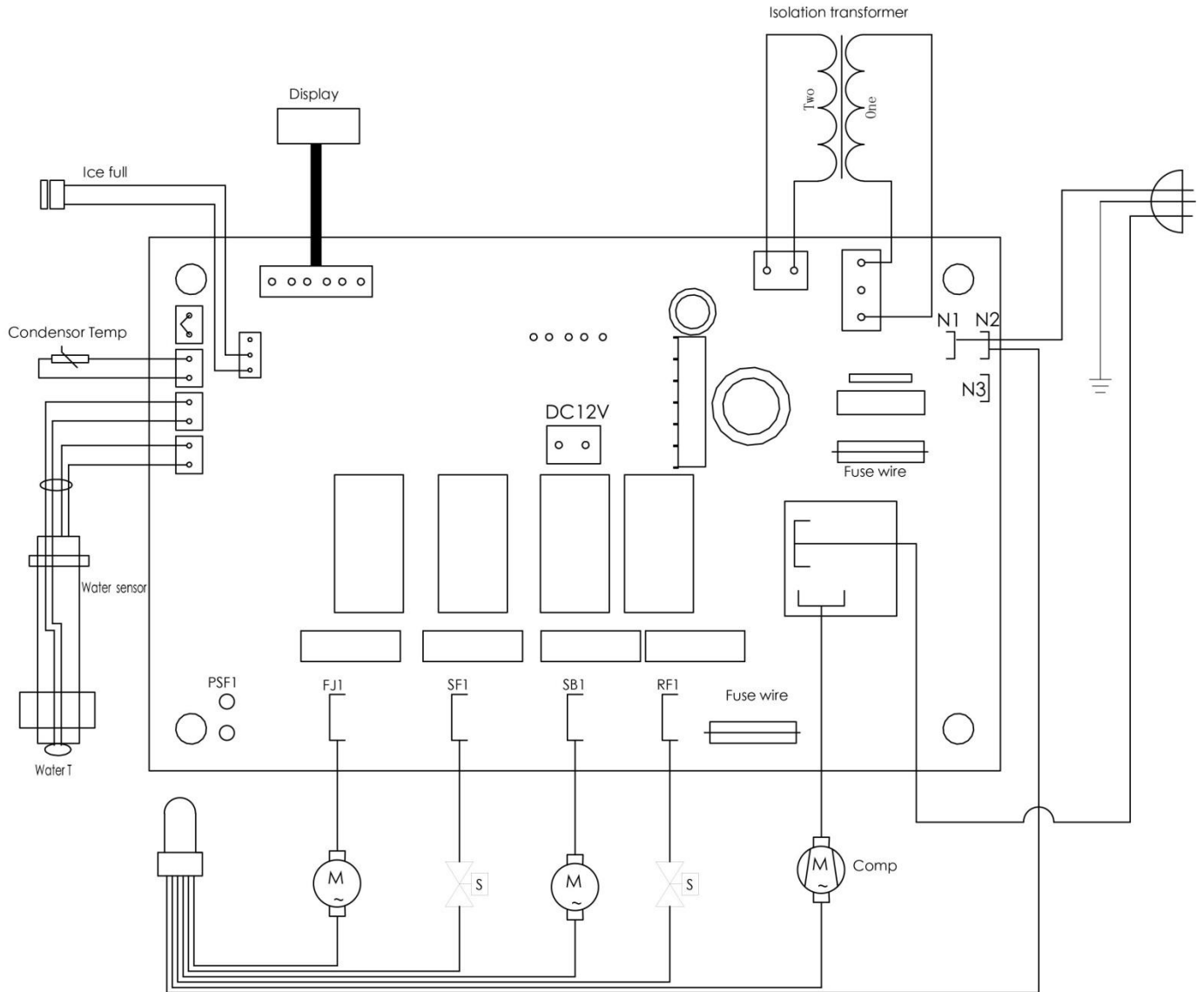

18. Exploded drawing

Assembly system

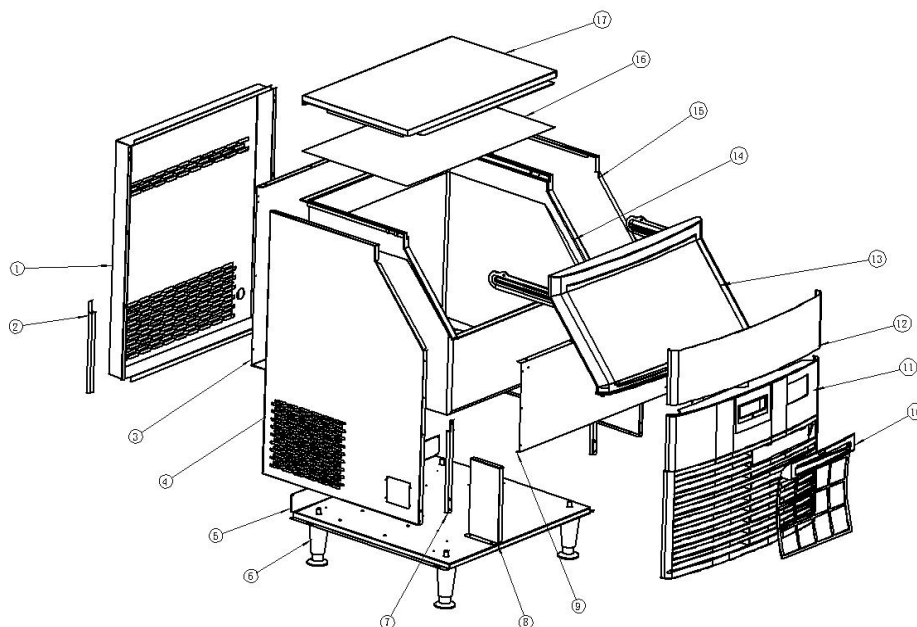

Serial number	Figure 1	IB200A	IB255A	IB320A
1	Backward back panel	1	1	1
2	Rear vertical bracket	2	2	2
3	A of inner guard	1	1	1
4	Left panel	1	1	1
5	Base panel	1	1	1
6	Machine foot	4	4	4
7	Front vertical bracket	2	2	2
8	Windscreen	/	/	1
9	B of inner guard	1	1	1
10	Filter	1	1	1
11	200P ventilation windows	1	1	1
12	Front trim panel	1	1	1
13	Door panels	1	1	1
14	Ice bin	1	1	1
15	Right panel	1	1	1
16	ABS board	1	1	1
17	Top panel	1	1	1

Refrigeration system

Refrigeration system

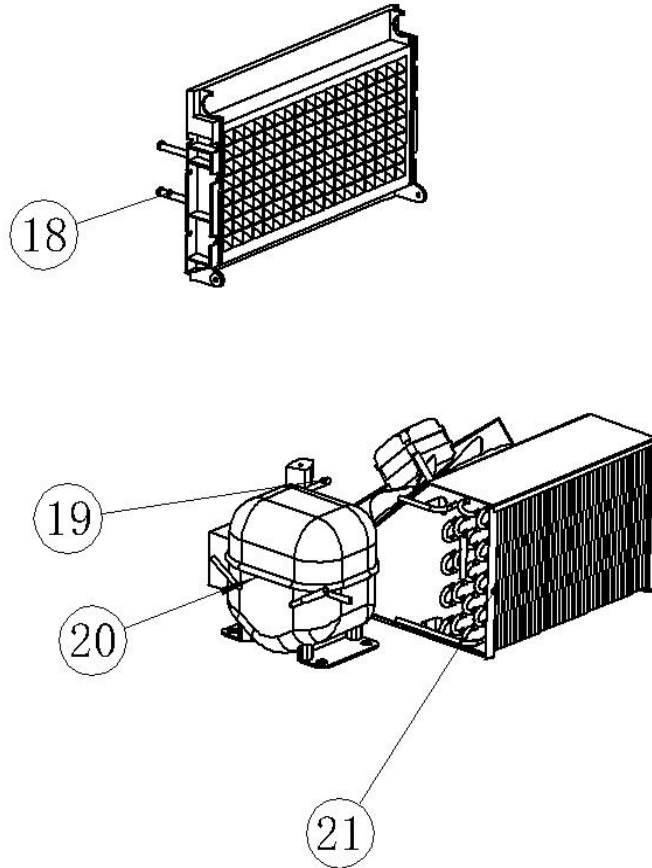

Serial number	Figure 1	IB200A	IB255A	IB320A
18	Ice	1	1	1
19	Solenoid valve	1	1	1
20	Compressor	1	1	1
21	Condenser	1	1	1

Water circulation system

Water circulation system

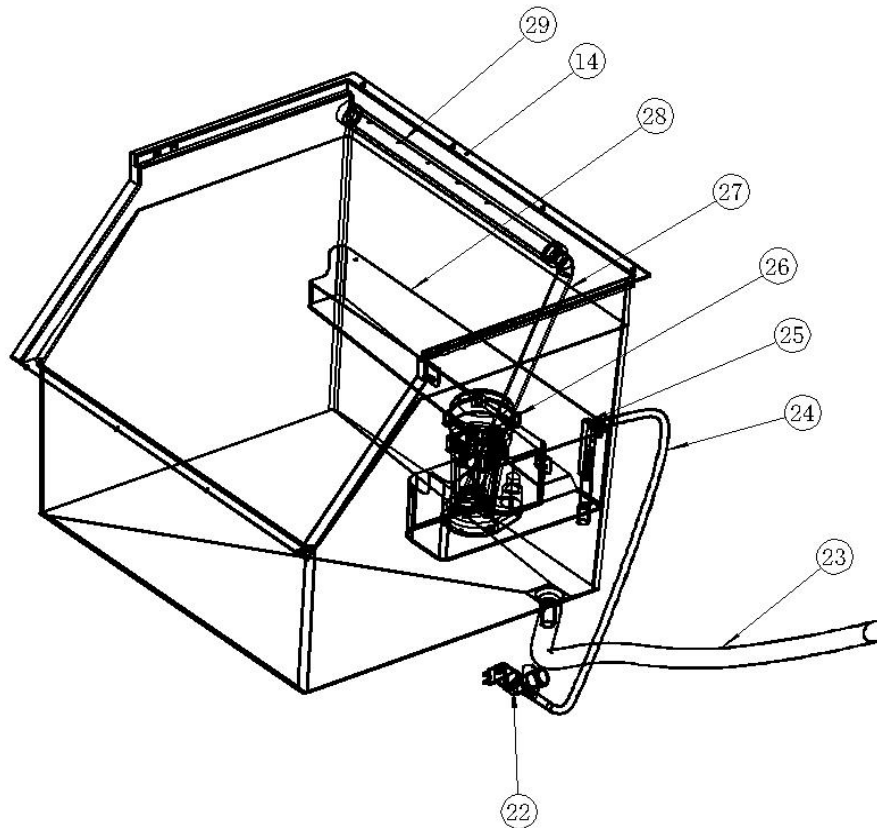

Serial number	Figure 1	IB200A	IB255A	IB320A
14	Ice bin	1	1	1
22	Water inlet valve	1	1	1
23	Drainage	1	1	1
24	Water inlet pipe	1	1	1
25	Feed pipe joints	1	1	1
26	Pump	1	1	1
27	Water mains	1	1	1
28	Flats	1	1	1
29	Flow pipe	1	1	1

Electric control system

Electric control system

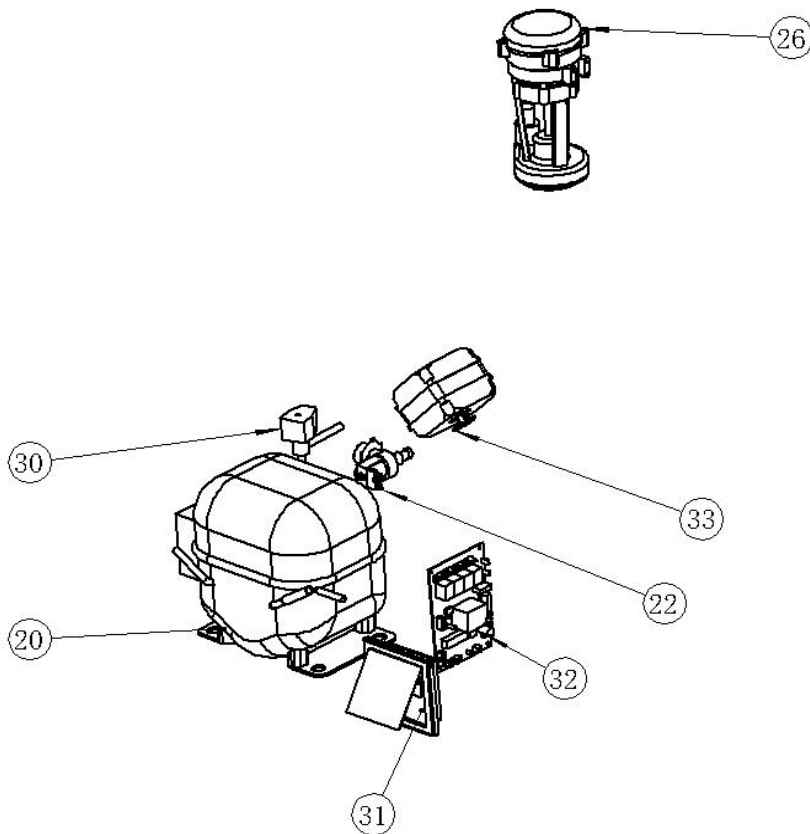

Serial number	Figure 1	IB200A	IB255A	IB320A
20	Compressor	1	1	1
22	Water inlet valve	1	1	1
26	Water Pump	1	1	1
30	solenoid valve coil	1	1	1
31	Touch screen	1	1	1
32	PC Board	1	1	1
33	EBM motor	1	1	1