

**VEVOR<sup>®</sup>**

**GARDEN JET PUMP**  
**INSTRUCTION MANUAL**

# VEVOR<sup>®</sup>

## GARDEN JET PUMP

**XKJ-805S-1**

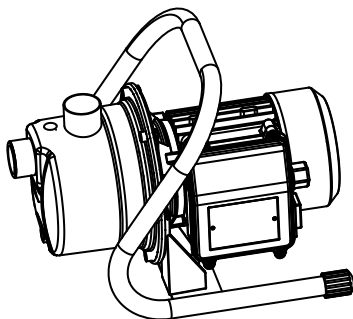

**XKJ-1105S**

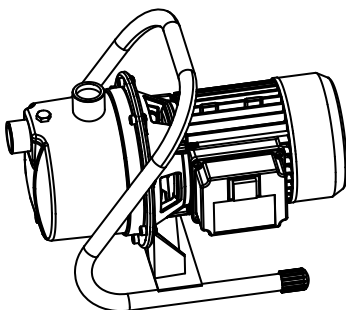

### NEED HELP? CONTACT US!

Have product questions? Need technical support? Please feel free to contact us:

**CustomerService@vevor.com**

This is the original instructions, please read all manual instructions carefully before operating. VEVOR reserves clear interpretation of our user manual. The appearance of the product shall be subject to the product you received. Please forgive us that we won't inform you again if there is any technology or software updates on our product.

This appliance can be used by people aged 8 years and above and persons with reduced physical, sensory or mental capabilities or lack of experience and knowledge if they have been given supervision or instruction concerning the use of the appliance in a safe way and understand the hazards involved. Children shall not play with the appliance. Cleaning and user maintenance shall not be made by children without supervision.

**Attention!**

If the appliance or the supply cord is damaged, it must be repaired by the manufacturer, its service agent or a qualified person.



Meaning of crossed-out wheeled dustbin:

Do not dispose of electrical appliances as unsorted municipal waste, use separate collection facilities. Contact your local government for information regarding the collection systems available.



Read the instructions carefully and follow the rules for safe operation. The operator shall take full responsibility for personal injury, pump damage and other property losses caused by violation of safety cautions.

## APPLICATIONS

It is applicable to household water supply, equipment support, well water lifting, pipeline pressurization, garden watering, vegetable greenhouse watering, fish farming and poultry raising, etc.

Transfer clean water and other non-corrosive liquids with low viscosity; do not transport inflammable, explosive, gasified liquids and liquids containing solid particles or fibers. The liquid PH value shall be between 6.5 and 8.5.

**Remark:**

The pump can work automatically, equipped with a pressure tank, a pressure switch and other necessary parts. Function features of the automatic pump are as follows: when the power is on, turn on the water tap and the pump will start working automatically; when the water tap is turned off, the pump will stop working automatically. If a water tower is used along with the automatic pump, connect to the upper limit switch and the pump will start or stop working automatically with the water level in the water tower.

## TECHNICAL DATA

Model	XKJ-805S-1	XKJ-1105S
Nominal voltage	115V~, 60Hz	110-120V~, 60Hz
Amp	7A	10A
Max.head	40m	50m
Max.flow	3.7m <sup>3</sup> /h	4.5m <sup>3</sup> /h
Max.Suction depth	8m	8m
Protection class	IPX4	IPX4
Insulation class	F	F
Max.ambient temperature	+40°C	+40°C
Max.liquid temperature	+35°C	+35°C

# SAFETY PRECAUTIONS

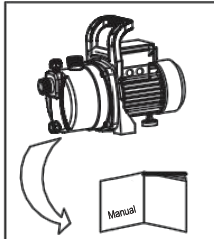

1. To ensure normal and safe operation of the electric pump, read the manual carefully before use.

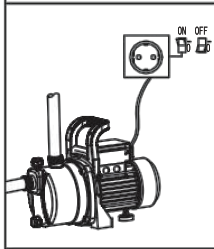

2. To avoid electric shock, make sure the pump is safely grounded and equipped with an earth leakage circuit breaker. Do not get the plug wet and do not use any socket in an area with high humidity.

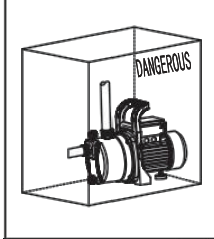

3. Do not touch the electric pump while working; do not wash, swim near the working area or let livestock into the water to avoid accidents.

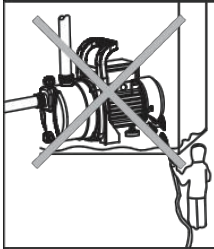

4. Avoid splashing pressured water to the electric pump. Do not immerse the pump in water.

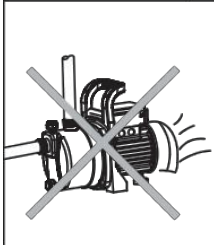

5. Keep the pump in a well-ventilated place.

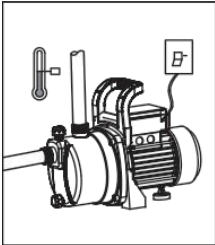

6. If the environment temperature is below 4°C or after a long period of non-use, the liquid inside shall be discharged for freeze and frost protection.

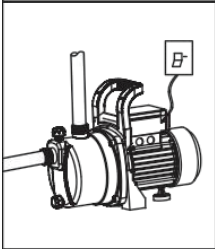

7. The pumped liquid may be hot and under high pressure, so before moving and disassembling the pump, valves in both sides of the pump should be turned off first and then empty liquids in the pump and pipelines so as not to be scalded.

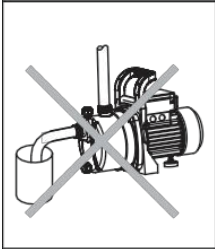

8. Never use the pump to transport inflammable, gasifying or explosive liquid that exceeds the specified liquids in this manual.

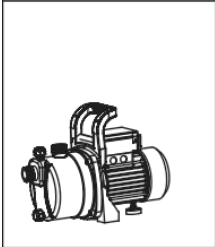

9. The power supply should be in accordance with the voltage stated in the nameplate. If the pump is not be used for a long time, empty it completely, wash it with clean water and store it in a dry, well-aired place.

# PIPELINE INSTALLATION



This product shall be installed and maintained by a qualified person who is proficient with this instruction. The installation and operation must be in accordance with local regulations and the recognized operation criteria. Install the pipeline properly according to the requirement of this instruction, and protect it from freezing.

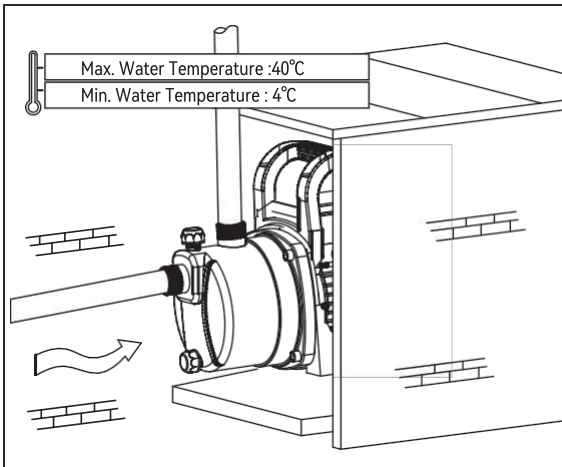

1. Make the inlet pipeline as short as possible and keep bends as few as possible during installation. Keep the pump in a dry and well-ventilated place. In condition of outdoor installation, make sure the pump is properly protected by weather-proof covering.
2. Installation of valves on inlet and out let pipelines is necessary. The valve installed on inlet pipeline shall be one-way valve.

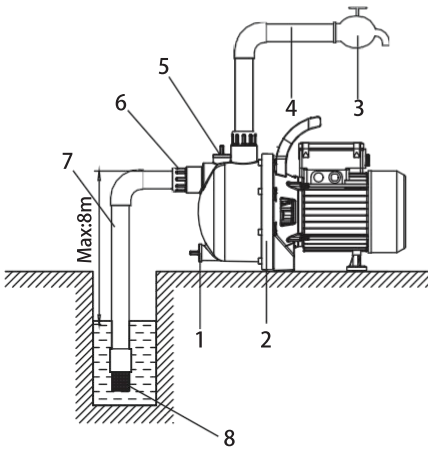

**Correct Installation Diagram** **A**

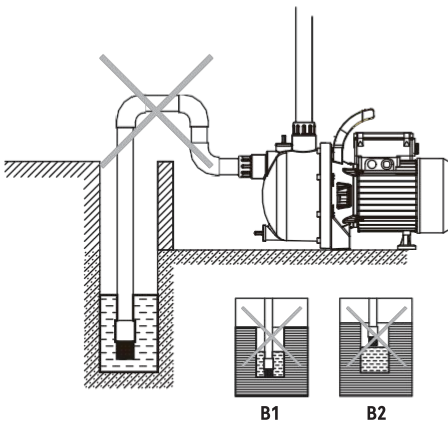

**Incorrect Installation Diagram** **B**

**A:**

- |                  |                 |
|------------------|-----------------|
| 1. Drain plug    | 5. Filling plug |
| 2. Electric pump | 6. Tie-in       |
| 3. Water tap     | 7. Inlet pipe   |
| 4. Outlet pipe   | 8. Foot valve   |

**Notes for inlet pipeline installation:**

- 1). Do not use soft rubber tube for inlet pipeline during pump installation.
- 2). The bottom valve shall be vertically installed with a distance of 30 cm from the water bottom to avoid suction of sediment (B1).
- 3). All connections of the inlet pipeline must be sealed. To ensure water suction, it's necessary to reduce the quantity of bents of the pipeline.
- 4). The diameter of inlet pipeline must not be less than that of the pump inlet to avoid big hydraulic loss and small water flow.
- 5). Pay attention to the water level during operation. The bottom valve shall not be above the water surface (B2).
- 6). In case the inlet pipeline is more than 10 m in length or over 4 m in hoisting height, the diameter of the inlet pipeline must be bigger than

**Note for outlet pipeline installation:**

The diameter of the outlet pipeline shall be not less than that of the pump outlet to reduce the pressure drop, high flow rate and



## START-UP AND MAINTENANCE



- Do not switch on the pump if the pump chamber is not fully filled with water.
- Do not touch the electric pump unless the power of pump is cut off for over 5 minutes.
- Do not remove the pump bonnet unless the water in pump chamber is completely drained.

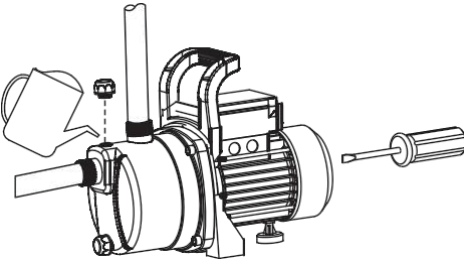

Stir the fan with a screwdriver to check if the pump rotates flexibly before startup. Remove the filling plug and prime the pump chamber fully with clean water, then screw the filling plug. Keep the valve wide opened during startup. When the pump runs normally, adjust the valve to the required flow (The range of flow and head is shown on the nameplate).

### Note:

- 1). If no water can be pumped in 5 minutes after the pump is filled with water and started up, turn off and refill the pump, or check the leakage of inlet pipelines, then restart the pump.
- 2). For frost and freeze protection, remove the discharge plug on the air tank and drain the water in the pump chamber completely. Before restarting the pump, it's necessary to remove the filling plug, fill the pump fully with water, and then screw the filling plug.
- 3). If not used for a long time, discharge the water in the pump chamber and store the pump in a dry, well-ventilated place.
- 4). If the ambient temperature is high, make sure the pump works in a well-ventilated place to avoid electrical faults caused by dew on electrical parts.
- 5). In the case of overheat or abnormal operation of the pump motor, cut off the power supply immediately, and check the faults according to the following form.

# TROUBLESHOOTING



Check the pump after power cut-off.

Symptom	Cause	Corrective Action
The motor can not be started	Single-phase power supply (three-phase electric motor): a. poor connection of the power switch; b. fuse is burned out; c. loose power lead; d. phase failure of the cable.	a. repair switch contactor replace the switch; b. replace the safety fuse; c. check and tighten the power connector; d. repair or replace cables.
	The capacitor is burned out.	Replace with a same type capacitor (send to the maintenance point for repair).
	The rotating shaft and bearing are jammed.	Replace the bearing (send to the maintenance point for repair).
	The impeller is jammed.	Turn the rotating shaft of the fan blade terminal with a screwdriver to let it rotate flexibly or demount the pump body to clear sundries.
	The stator winding is damaged.	Replace winding coils (send to the maintenance point for repair).
The motor is in operation, but no water is discharged	Incorrect direction of pump rotation.	Invert two-phase wirings of the motor (three-phase motor).
	The pump is not fully filled with water.	Re-fill the pump with water.
	The impeller is damaged.	Replace the impeller (send to the maintenance point for repair).
	Leakage of the suction pipe.	Check the tightness of various joints of the inlet pipelines.
	Water level is too low.	Adjust installation height of the pump.
	Freeze caused by accumulated water in the pipeline or the chamber.	Start up the pump after the ice is melted.
	Water that is too hot can result in the failure of plastic parts.	Replace the damaged parts (send to the maintenance point for repair).

<b>Symptom</b>	<b>Cause</b>	<b>Corrective Action</b>
Insufficient pressure.	Incorrect pump type.	Select a suitable model.
	The inlet pipeline is too long or with too many bends, or/and the pipe diameter is not selected as required.	Apply the pipe with the stipulated diameter, and make the inlet pipe short.
	The inlet pipeline, filter screen or pump chamber is blocked by foreign materials.	Clean pipeline, foot valve or pump chamber, clear foreign materials.
Motor works intermittently or the stator winding is burned out	The impeller is jammed or in overload operation for a long time.	Clear foreign materials in the pump chamber; operate the pump under the rated flow.
	Incorrect grounding, broken cable or the electric pump is struck by lightning.	Properly grounded, replace the broken cable, and replace winding coils.

E-mail: [CustomerService@vevor.com](mailto:CustomerService@vevor.com)

Manufacturer: Leo Group Pump(Zhejiang) Co., Ltd.

Add: NO.1, 3rd Street, East Industry Center, Wenling 317500 Zhejiang P.R. China.

Made in China

**VEVOR<sup>®</sup>**

E-mail: [CustomerService@vevor.com](mailto:CustomerService@vevor.com)