

**VEVOR<sup>®</sup>**

**WET&DRY VACUUM CLEANER  
INSTRUCTION MANUAL**



# VEVOR<sup>®</sup>

## WET&DRY VACUUM CLEANER

BJ1623-10



Please read the manual clearly before using it and keep it properly for future use.

### NEED HELP? CONTACT US!

Have product questions? Need technical support? Please feel free to contact us:

**CustomerService@vevor.com**

This is the original instructions, please read all manual instructions carefully before operating. VEVOR reserves clear interpretation of our user manual. The appearance of the product shall be subject to the product you received. Please forgive us that we won't inform you again if there is any technology or software updates on our product.

# PARTS DESCRIPTION



## Accessories:



Hose



2-in-1 Utility Nozzle



Deluxe Car Nozzle



2 in 1 Crevice Nozzle



Cloth Filter (Dry)



Foam Filter(Wet)

## **WARNING!**

1. Do not leave the appliance when plugged in. Unplug from outlet when not in use and before servicing.
2. Do not use it outdoors or on wet surfaces.
3. Do not allow it to be used as a toy. Careful attention is necessary when used by or near children.
4. Use only as described in this manual. Use only the manufacturer's recommended attachments.
5. Do not use a damaged cord or plug. If the appliance is not working as it should, has been dropped, damaged, left outdoors, or dropped into water, please return it to a service center.
6. Do not pull or carry by cord, do not use cord as a handle, or pull cord around sharp edges or corners. Do not run this vacuum over the cord. Keep the cord away from heated surfaces.
7. Do not unplug by dragging the cord. To unplug, drag the plug, not the cord.
8. Do not use the plug or the vacuum with wet hands.
9. Do not put any object into the suction inlet. Do not use any inlet with blockages; keep free from dust, lint, hair, and anything that may reduce airflow.
10. Keep hair, clothes, fingers, and all parts of your body away from the vacuum when it is in use.
11. Turn off the vacuum before unplugging.
12. Use it extra care when cleaning on stairs.
13. Do not use to pick up flammable or combustible liquids, such as gasoline, or use in areas where they may be present.
14. Do not pick up anything that is burning or smoking, such as cigarettes, matches, or hot ashes.
15. Do not use the vacuum without the dust bag and/or the filter.
16. This appliance is provided with double insulation. Please use identical replacement parts. See instructions for Servicing of Double-Insulated Appliances.
17. This appliance is equipped with a polarized plug (one blade is wider than the other). To reduce the risk of electric shock, this plug is only intended to fit in a polarized outlet. If the plug does not fit the outlet, please reverse the plug. If it still does not fit, contact a qualified electrician. Do not modify the plug in any way.

### **SAVE THESE INSTRUCTIONS**

#### **SERVICING OF DOUBLE-INSULATED APPLIANCES**

A double-insulated appliance is marked with one or more of the following: The words "DOUBLE INSULATION" or "DOUBLE INSULATED" or the double insulation symbol (square within a square).



In a double-insulated appliance, two systems of insulation are provided instead of grounding. No grounding means is provided on a double-insulated appliance, nor should a means for grounding be added to the appliance. Servicing a double-insulated appliance requires extreme care and knowledge of the system, and should be done only by qualified service personnel. Replacement parts for a double-insulated appliance must be identical to the parts they replace.

# FUNCTIONAL OPERATION INSTRUCTIONS

1. Take out the product and accessories from the box and check that the accessories and equipment are in good condition.
2. Loosen the latches, pick up the main part, remove the attachment from the dust collector, and check if the filter is installed in place.
3. There are special screws and gaskets in the package, fix the casters to the axle of the base with screws and gaskets.
4. Connect the hose to the inlet, and then connect any nozzles or brush to the other end of the hose.
5. Plug in the power cord, press the power switch and then start working.
6. When using the water absorption function, do not forget to change the cloth filter to the foam filter, ensuring the security work.
7. Product installation and function introduction diagram:

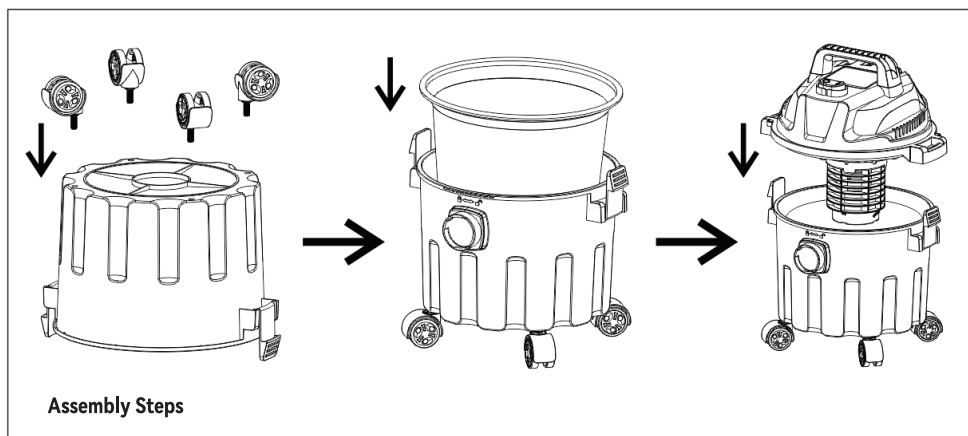

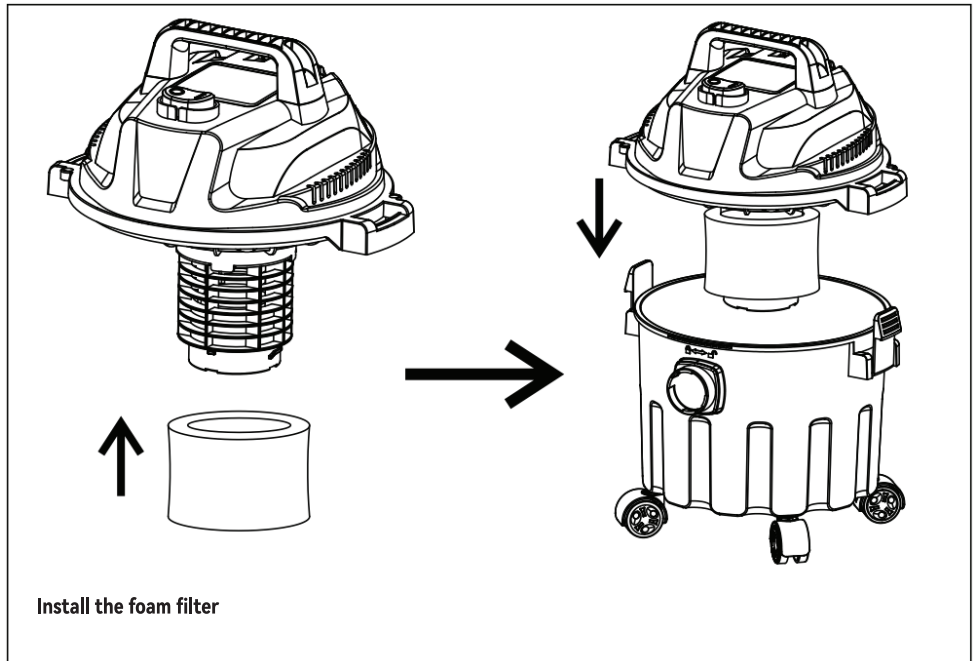
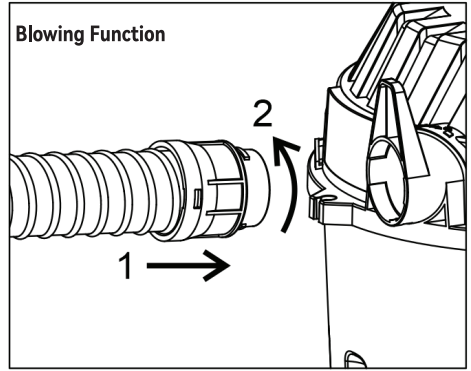
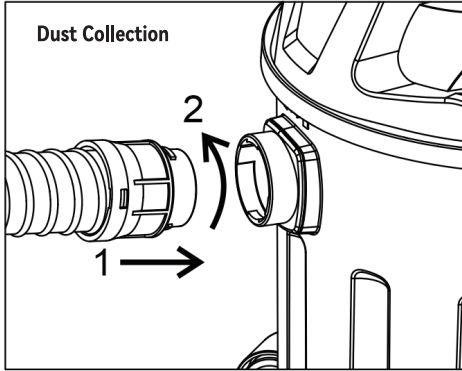

## PROTECTIVE DEVICE

### Special instructions for protective devices

When the tank is filled with water, the device rises, the vacuum power supply stops, and abnormal noise indicates that the motor is running at high speed. If this happens, you should cut off the power and pour out the water. Restore the power and it will start working properly again.

When the vacuum cleaner flips or shakes, the device is working properly, the power should be cut off and made upright, and then turn on the machine again.

When the tank is filled with water, the device will rise, the suction will be cut off, please stop working immediately.

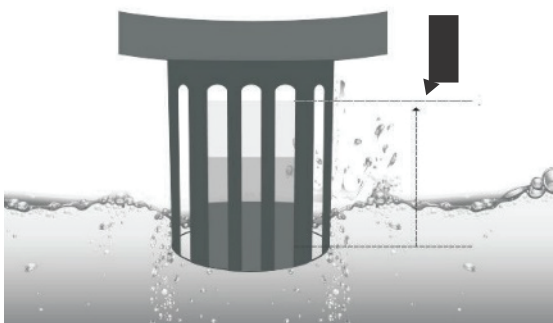

## USE REQUIREMENTS

- ⊘ Do not use the machine in combustible and explosive places in case the motor gets burned.
- ⊘ Check the hose inlet is not blocked, in case the temperature rises and damages the motor.
- ⊘ Do not collect combustible and explosive objects such as cigarettes, gasoline, etc.
- ⊘ Do not collect sharp objects.
- ⊘ Do not collect objects which can easily attach to the filter such as lime powder, gypsum and graphite powder, for these will block the ventilation and damage the motor.
- ⊘ Turn off the machine and remove the plug each time after using it or when it is being repaired.
- ⊘ Keep the machine away from strong sunlight and high temperature places in case its body would be deformed.



## CLEANING AND MAINTENANCE

Before cleaning, please turn off the power switch first and pull out the power plug. Take out the filter and flush it with water. It is recommended to use tap water to clean the dust on the filter. Put the filter in a well-ventilated place and dry it naturally for the next use or storage.

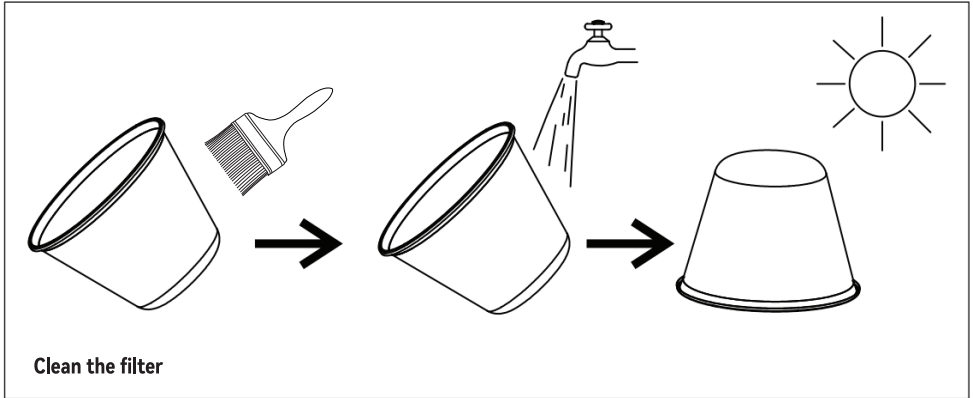

- Shake off the water droplet and dry it . ( To prevent peculiar smell or blockage.)
- Do not dry it with an blower and other hot wind. (To prevent deformation.)
- It is prohibited to use detergent, bleaching agent, diluent, alcohol, etc. ( To avoid crack, color changing, etc.)

## FAULT ANALYSIS

Fault	Probable Cause	Solution
Machine Operation Failure	<ol style="list-style-type: none"> <li>1. Check whether the power plug is firmly inserted into the socket.</li> <li>2. Check whether there is electricity of the power socket.</li> </ol>	<ol style="list-style-type: none"> <li>1. Reinsert the plug into the socket.</li> <li>2. Ensure that there is electricity of the power socket.</li> </ol>
Suction Is Weak	<ol style="list-style-type: none"> <li>1. Check whether the nozzles or hose are blocked.</li> <li>2. Check whether the bucket and the main part are well assembled.</li> <li>3. Check whether the filter is blocked.</li> </ol>	<ol style="list-style-type: none"> <li>1. Clean the blockage in time.</li> <li>2. Reassemble in place.</li> <li>3. Clean or replace the filter.</li> </ol>
Abnormal Noise	<ol style="list-style-type: none"> <li>1. Check whether the filter is blocked.</li> </ol>	<ol style="list-style-type: none"> <li>1. Please clean the filter in time.</li> </ol>

Please send the machine to our maintenance center if the faults cannot be fixed according to the above solutions. You had better not disassemble the vacuum without professional reference.

**Manufacturer:** Yongkang Sippon Electric Co., Ltd.

**Add:** No. 75, Sifang Road, Xicheng Zone, Yongkang city, Zhejiang

**Made in China**



**VEVOR<sup>®</sup>**

E-mail: [CustomerService@vevor.com](mailto:CustomerService@vevor.com)