

VEVOR[®]

Model: DT5

USER MANUAL



The information in this handbook is correct at the time of printing. our company is responsible for recising and updating this handbook. However we reserve the right to modify and update our products and handbook without notice. This handbook contains sketches, which are to be used as a reference only. Please use common sense if these sketches is not exactly your situation or products.

◇ CONTROL PANEL

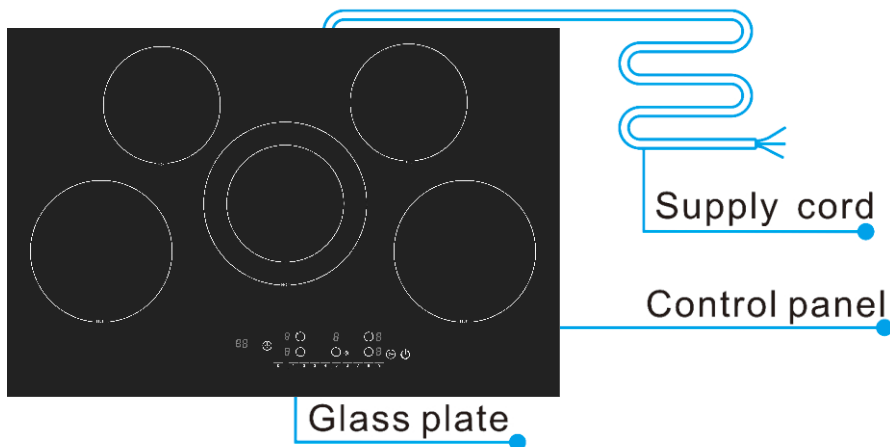

This panel schematic is suitable for 2/3/4/5/6 head furnace series.

◇ SCHEMATIC DIAGRAM OF THE CONTROL PANEL

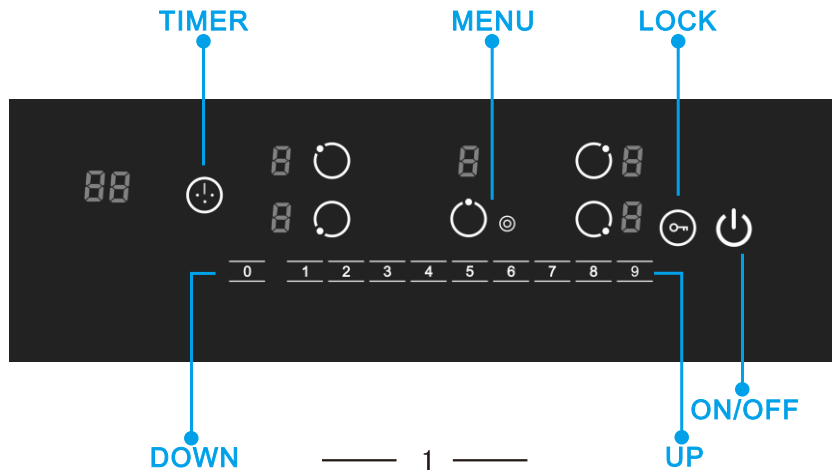

◇ INSTRUCTION

The product is quiet without fan, using high power relay motherboard without heat output. When the heating temperature reaches the upper limit of the program set value, the ceramic plate stops working, and starts working again when it is lower than the lower limit, so as to ensure that the constant temperature on the furnace surface is at the set temperature, saving energy and high efficiency



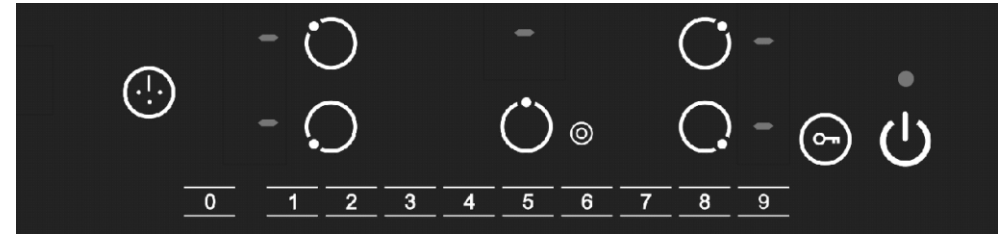

1. Power: when connected to the power supply, there is a sound of dripping, and all the displays shine at the same time.
2. Power button: Press the power button for 0.5 seconds and drop a sound to enter standby. The power indicator lights up and five furnace areas are displayed. (In standby state, when there is no operation for 10 seconds, five furnace areas - no display. When there is no operation within 2 minutes, one sound will automatically exit standby and return to shutdown state.

Standby state is shown as follows:

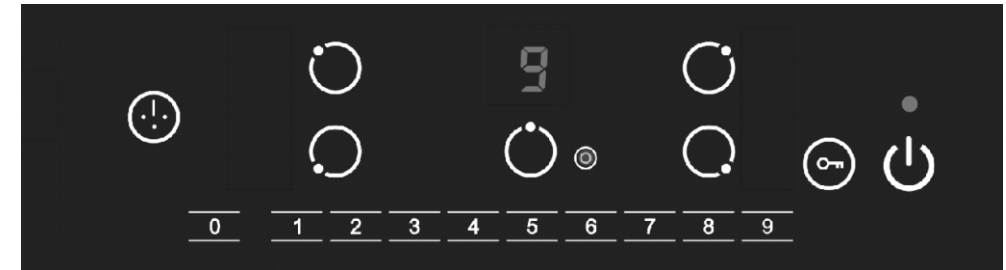

3. Heating: For example, if you want to use the middle furnace, press in standby state, there is a sound and digital display 0, it indicates that the furnace area is selected successfully, and then press the sliding area below to adjust the desired firepower gear, heating opening is completed. This furnace area is double ring heating Inner ring is turned on by default. When heating, press the button of furnace area again to switch single/double ring heating. Double ring heating side indicator light , indicating that the simultaneous heating of the double ring is enabled.





1.  165 Heating area of upper left furnace: Single ring Heating, power 240V/1000W □ / 1600W □
2.  200 heating area of lower left furnace: single ring heating, power 240V/2200W □ / 2000W.
3.  230 Heating zone: double ring Heating, power 240V/1000W □ / 2000W □
4.  165 Heating area of upper right furnace : Single ring Heating, power 240V/1000W □ / 1600W □
5.  200 Heating area of lower right furnace: single ring Heating, power 240V/2200W □ / 2000W.

4. Firepower adjustment: select the furnace area, slide or click the number below, 1 to 9 sections can be adjusted. Press 0 to stop heating for the selected burner.

5.  Child lock: Long press the child lock key for 2 seconds to make a sound to lock or unlock the child lock. The child lock indicator lights up and displays Lo when the lock is successfully locked. Can not operate when locked furnace area with fire timing adjustment, but can press the power off button.

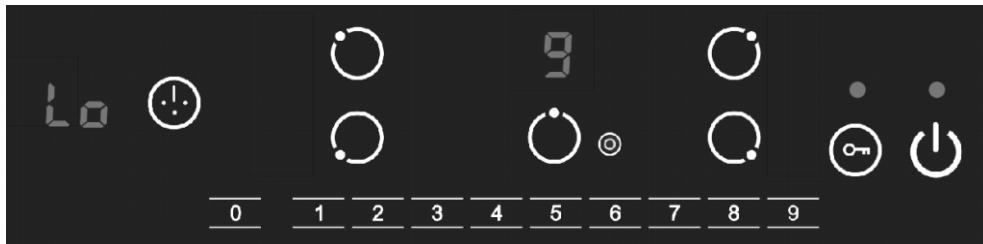
Locked successfully as shown in figure:



6.  Timing: This function is to set the shutdown time. In the heating mode, select the furnace area and press the timing button to enter the timing preset, and the corresponding timing indicator will be prompted. Then adjust the sliding area to set the shutdown time, you can also directly press the number, such as: first press the number 3 and then press the number 8 is 38 minutes. Multiple heating furnace areas can set different shutdown time at the same time.

As shown in the figure, timing upper left furnace area:

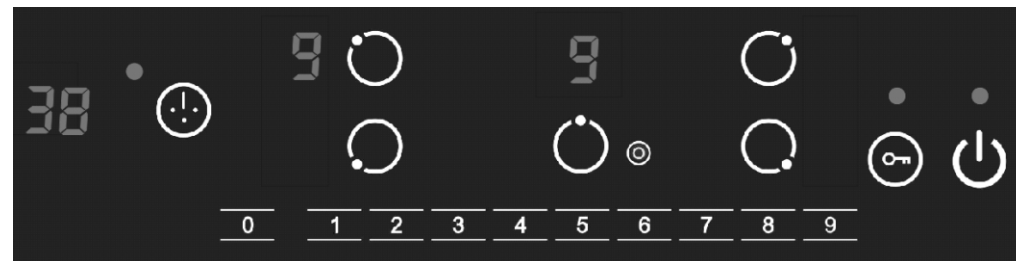

7. Panel high temperature warning: there is still residual temperature on the furnace panel after use, warning display H, be careful of scalding hands.

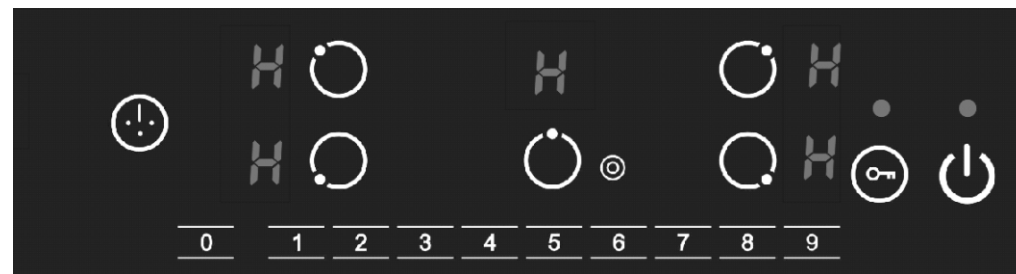

8. Product dimensions and precautions:

8.1. Product dimensions 770*520*78mm(30.3*20.47*3.07 in.) If not including the foot of the furnace product thickness is 55mm(2.16 in.).

8.2. Opening size 760*500*150mm (29.8*19.68*5.9 inches)

INSTALLATION EASILY

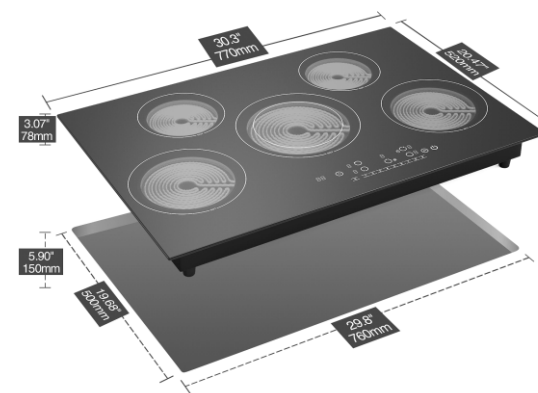

Note: if the product is used on the table, because the bottom of the use process will produce temperature, please use high temperature resistant flame retardant material for the table such as marble..... And so on.

9. Code:

E1----- Open the temperature sensor on the indicator board

E2----- The temperature sensor on the indicator board is short-circuited or the temperature around the indicator board is too high

H----- Panel still has residual temperature warning (which is explained in article 7 of normal warning)

H----- thermocouple open (standby and shutdown state will always flash and the corresponding furnace area is not heated)

Lo----- Locked state (explained in article 5)

10. Simple faults and troubleshooting: the furnace head is always heated at any gear, and the relay does not jump (thermocouple short circuit or motherboard fault)

◇ INSTALLATION

Owing to the high temperature inside the infrared cooker, make sure good ventilation is provided to assure its normal operation. As shown in Figure 2

Attention:

1. The electric hob is recommended to be installed by professional. Please never conduct the operation by yourself.
2. The wall and heating area above the table surface shall withstand heat.
3. To avoid danger the ceramic cooker hob must be installed into the cabinet before use.
4. Applicable cabinet material: wood, marble resin etc.

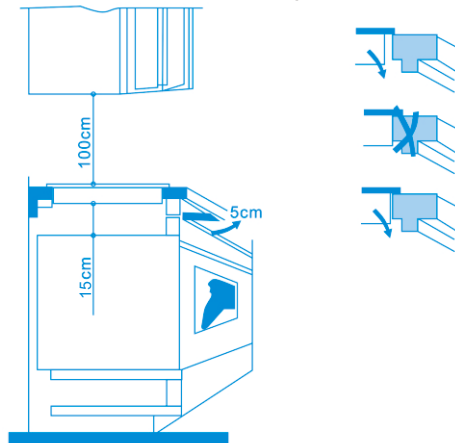

◇ SAFETY REMINDING

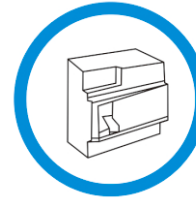

A dedicated power protection air switch must be incorporated in the fixed wiring in accordance with the wiring rules.



Never use the ceramic cooker hob in high temperature environment.



Never wash the ceramic cooker hob with water directly. Steam cleaner is not to be used.



Never have the cooker to work without food in pot, otherwise its operational performance may be affected and danger may happen.



For sealed foods such as canned goods, please do not heat them before opening their covers so as to avoid any dangers of explosion due to heating expansion.



The appliance is not intended to be used by children or handicapped persons, unless they have been supervised by a responsible person to ensure they can use it safely.



Do not place rough or uneven appliances, which may damage the ceramic surface.



If the surface is cracked, pull out the plug to avoid the possibility of electric shock.



Do not put any detergents or flammable materials in the equipment installed under the ceramic cooker hob.

◇ SAFETY REMINDING



Because the hob can generate very high temperature, please use a pot resistant to a temperature of over 200.



After being used the corresponding heating zone of the ceramic cooker is still hot. Never touch the ceramic cooker surface to avoid burn.



If the supply is damaged, it must be replaced by the manufacturer, its service agent or similarly qualified persons in order to avoid a hazard.

◇ CLEANING AND MAINTENANCE

1. Please shut off the power and pull out the plug before cleaning of the appliance.
2. Clean the appliance until it cools down completely.
3. To remove dirt, please select litmusless detergent.
4. After removing dirt, please use neat wet cloth to clean the unit..
5. Do not clean by water directly, water gets inside may cause malfunction.
6. Keep the ceramic plate and pan clean before cook, otherwise, dirt after charring is very difficult to clean and the plate may get discoloration
7. You may clean air vent/air entry's dirt by vacuum cleaner to suck up, if there is dirt with oil, add a little litmusless detergent with toothbrush to clean.
8. Don't use caustic impregnates to clean. It may damage the cooker by chemical reaction. Do not use benzene, scrubbing brush or polishing powder to clean the induction cooker.

◇ TROUBLE SHOOTING

1. If there is anything wrong with the stove, please check it as following before sending to repair.

No.	Problem	Possible causes
1	No indicator light when power "on"	1. Cable/terminal block is loose 2. Broken circuit or blown fuse 3. Power supply stopped
2	If there is "buzz" noise, and the "on/off" light flash, no heating	1. Please check if the pot is available 2. If the pot is in the centre of the ceramic plate
3	Appliance suddenly stops heating during operation	1. Air entrance or outlet blocked 2. Over-heating protection activated 3. Please check if the temperature around is too high 4. If the working time over defaulted working time, or the timer finish
4	No response for the key	Please check the plug is in right place.

2. Please do not open and repair the unit yourself avoid getting hurt and other risks.
3. If you fail to identify the problem, contact the after-sales service without delay.

◇ USABLE PANS

All flat bottom pots.
Please limit your food within 4kg.

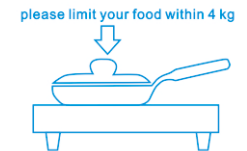

◇ POWER SUPPLY INSTALLATION DRAWING

Electrical diagram of the beautiful line (black, white, green E)

This figure is only for three-phase power in the United States, and the voltage between two live lines is 240VAC

Three core cable machine connection drawing

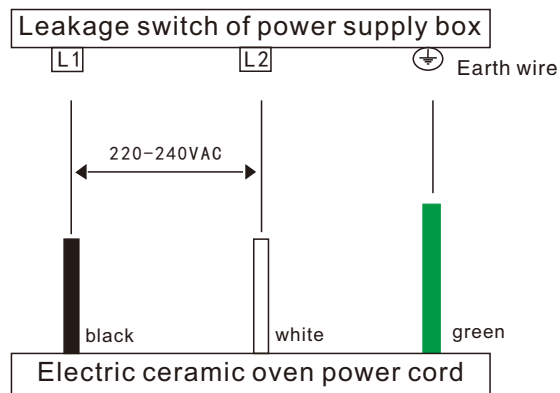
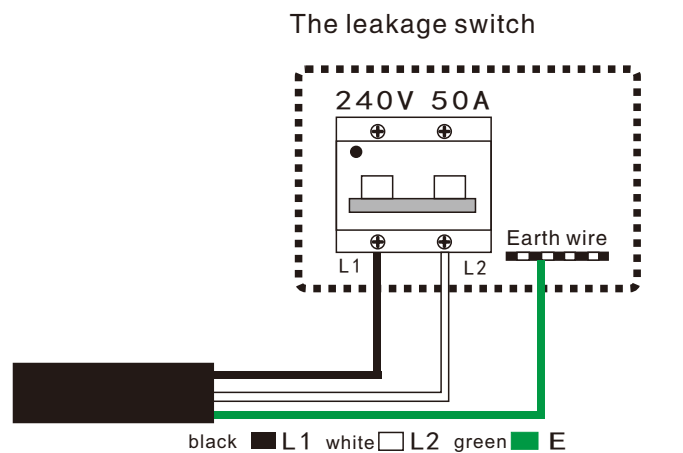

Electrical diagram of the beautiful line (black, white, green E)

This chart is only applicable to 220 V single-phase power countries in Europe and China

Three core cable machine connection drawing

