

Operation Manual

component instructions

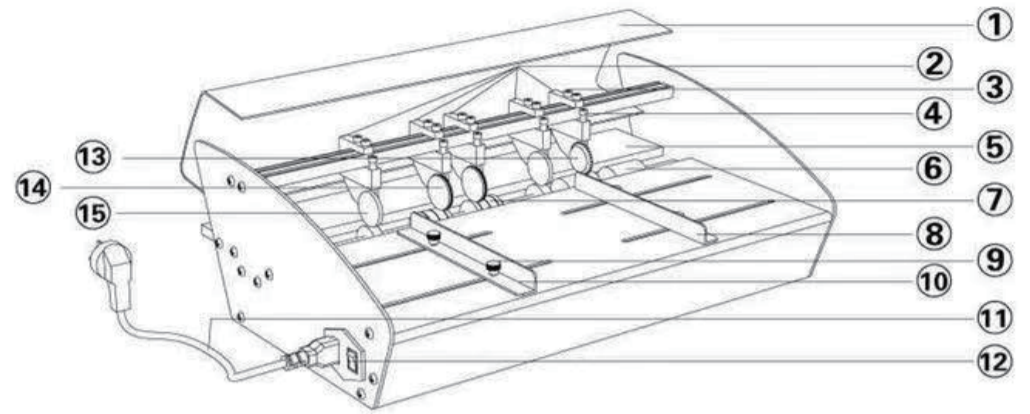

- ① cover
- ② tool rest
- ③ Head screw
- ④ Pressure adjusting screw
- ⑤ paper platform
- ⑥ bottom wheel
- ⑦ rolling groove wheel
- ⑧ Right paper positioning
- ⑨ adjusting screw
- ⑩ left paper positioning
- ⑪ power line
- ⑫ power switch
- ⑬ perforate wheel
- ⑭ creasing wheel
- ⑮ paper press wheel

operation instruction

operation instruction

Operation instruction

1. take out the machine, put on the flat table.

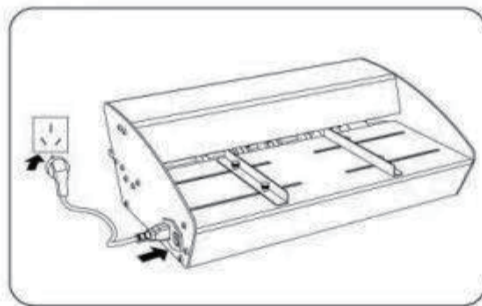

2. plug in, turn on the power switch, check the machine if it can run at constant speed.

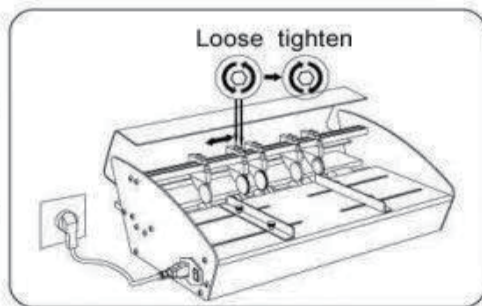

3. adjusting the creasing position and indentation number according to your needs, the upper indent should align to the suitable groove center.

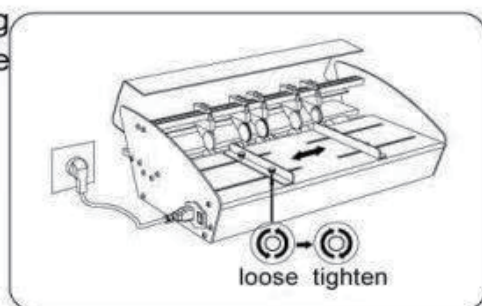

4. adjust the right and left postioning according to the paper size, the scale only for reference, you can fine adjusting the specific direction.

5. put in suitable paper, adjust the creasing pressure and feeding pressure. Different paper with different creasing pressure.

You can adjust the right and left press wheel, usually the left pressure wheel with a little bigger pressure.

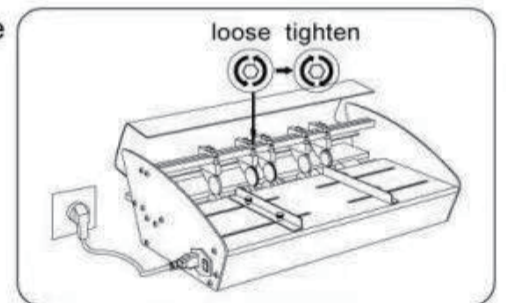

6. continue feeding paper manually, the creasing operation finished.

7. if you want to do perforating, adjust the perforating blade and shim to the suitable position, adjust the pressure to do perforating.

Parameter:

creasing wheel	2
paper pressing wheel	2
perforating wheel	1
dimension	510x325x172mm
N.G.	9.9kg
POWER	220V~240V 50HZ~60HZ