

VEVOR[®]

TOUGH TOOLS, HALF PRICE

Technical Support and E-Warranty Certificate

www.vevor.com/support

GEM FACETING MACHINE USER MANUAL

We continue to be committed to offering tools at competitive prices. "Save Half", "Half Price", or any other similar expressions used by us only represent an estimate of savings you might benefit from buying certain tools with us compared to the major top brands and do not necessarily mean to cover all categories of tools offered by us. You are kindly reminded to verify carefully when placing an order with us if you are saving half in comparison with the top major brands.

VEVOR[®]

GEM FACETING MACHINE

MODEL:KD-8801



NEED HELP? CONTACT US!

Have product questions? Need technical support? Please feel free to contact us:

✉ CustomerService@vevor.com

This is the original instruction, please read all manual instructions carefully before operating. VEVOR reserves a clear interpretation of our user manual. The appearance of the product shall be subject to the product you received. Please forgive us that we won't inform you again if there are any technology or software updates on our product.



Warning-To reduce the risk of injury, user must read instructions manual carefully.



This device complies with Part 15 of the FCC Rules. Operation is subject to the following two conditions:(1)This device may not cause harmful interference, and (2)this device must accept any interference received, including interference that may cause undesired operation.

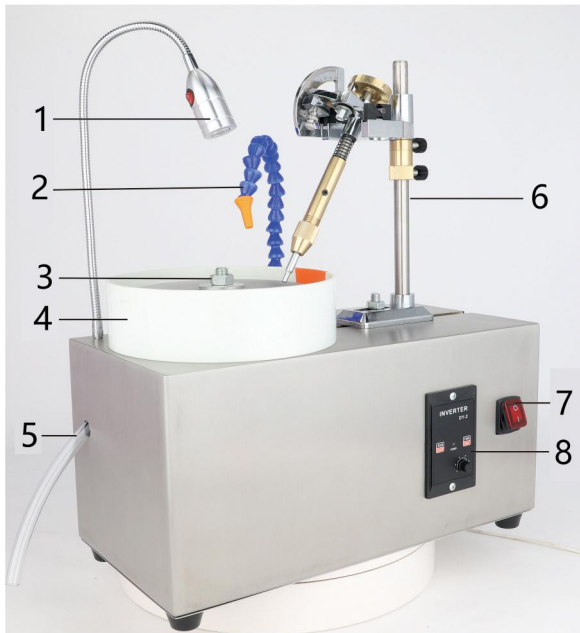

1. LED light
2. Bamboo pipe
3. secure the millstone
4. water tray
5. drainage pipes
6. manipulator
7. switch
8. frequency converter



Fittings of a machine:

1. Diamond millstone
2. Tray
3. Adaptor
4. Cooling water pipes
5. Screw
6. Three different gem fixing rod

GENERAL SAFETY RULES

WARNING: Do not attempt to operate the machine until you have read thoroughly and understood completely all instructions, rules, etc. contained in this manual. Failure to comply may result in accidents involving fire, electric shock, or serious personal injury. Keep this owner's manual and review frequently for continuous safe operation.

1. Know your machine. For your own safety, read the owner's manual carefully. Learn its application and limitations, as well as specific potential hazards pertinent to this machine.
2. Make sure all tools are properly earthed.
3. Keep guards in place and in working order. If a guard must be removed for maintenance or cleaning, make sure it is properly replaced before using the machine again.
4. Keep your work area clean. Cluttered areas and workbenches increase the chance of an accident.
5. Do not use in dangerous environments. Do not use power tools in damp or wet locations, or expose them to rain. Keep work areas well illuminated.
6. Keep children away. All visitors should be kept a safe distance from the work area.

7. Do not force the machine. It will do the job better and be safer at the rate for which it is designed.
8. Use the right tools. Do not force the machine or attachments to do a job for which they are not designed. Contact the manufacturer or distributor if there is any question about the machine's suitability for a particular task.
9. Wear proper apparel. Avoid loose clothing, gloves, ties, rings, bracelets, and jewellery which could get caught in moving parts. Non-slip footwear is recommended. Wear protective hair covering to contain long hair.
10. Do not over-reach. Keep proper footing and balance at all times.
11. Maintain the machine in good condition. Keep the machine clean for best and safest performance. Follow instructions for lubrication and changing accessories.
12. Disconnect the machine from power source before servicing and when changing the blade.
13. Never leave the machine running unattended. Turn the power off. Do not leave the machine until it comes to a complete stop.
14. Do not use any power tools while under the effects of drugs, alcohol or medication.
15. Always wear a face or dust mask if operation creates a lot of dust and/or chips. Always operate the tool in a well ventilated area and provide for proper dust removal. Use a suitable dust extractor.



Controller 1. The Stop/Start button. 2. Indicator light. 3. Rotate forward and backward buttons. 4. Speed regulating potentiometer knob adjustable speed range 0-2980 RPM. 5. Machine switch



To fix the screws of the manipulator, the manipulator can move forward and backward

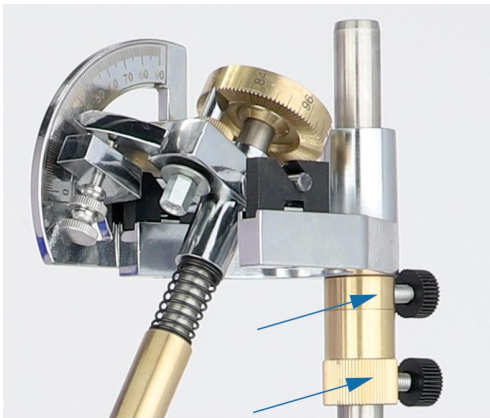

Height adjuster, used to adjust the angle between the operator and the grinding disc, that is, the angle of the workpiece. Unilateral rotation for fine adjustment

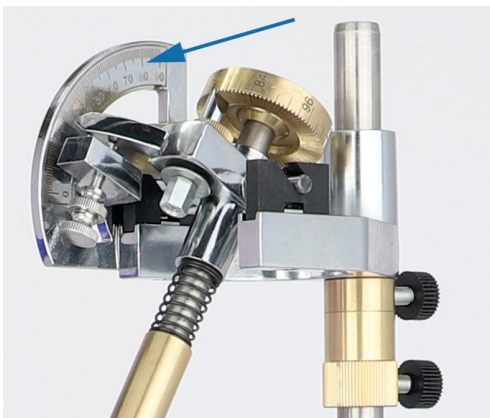

Fan angle card

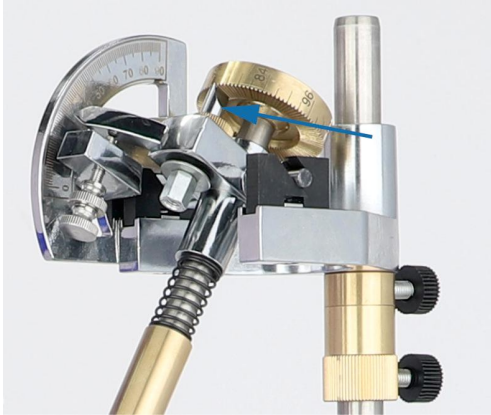

Dial indexing pin

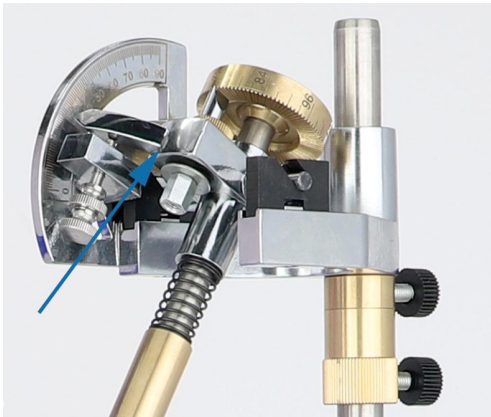

Hand control lever controls gem Angle

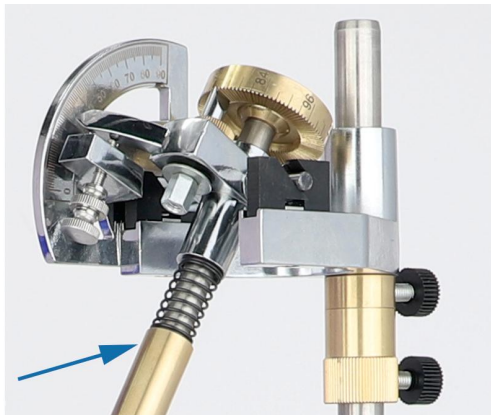

The manual control lever can be disassembled to adjust the angle and disassemble the gem.

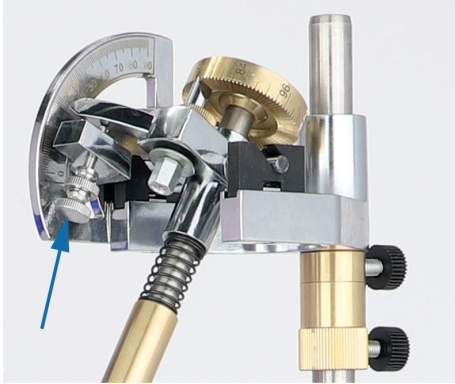

Screw control 90 degree fine tuning angle

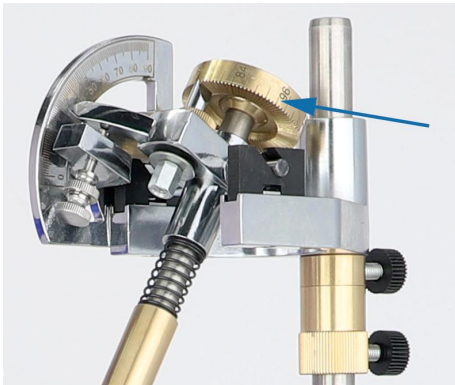

With the positioning rotation of 96 scale, can accurately control the gem Angle

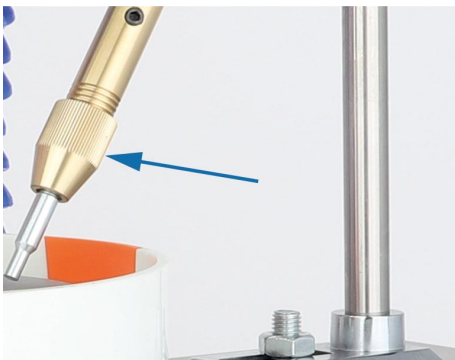

Rotate and fix the slime stick

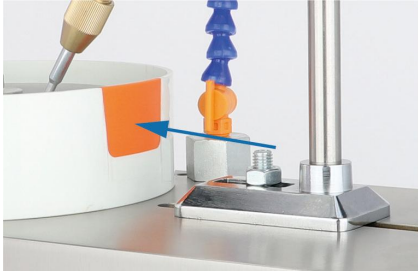

Remove the orange baffle on the water baffle plate, which can give the stone surface grinding

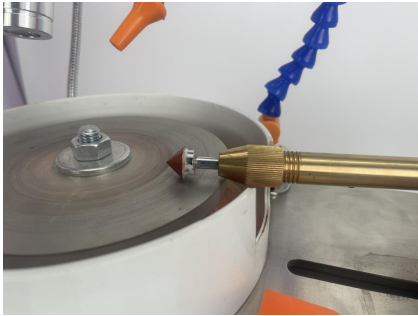

Gem surface grinding



LED light switch

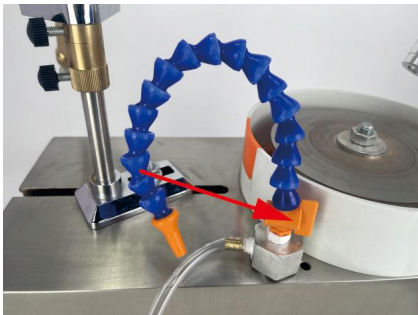

Tap switch, can control the water outlet



The faucet is connected to the water pump



Drain pipe



1. Power socket. 2. If any indicator light is off, please check the fuse

WARNING!

This manual provides critical safety instructions on the proper setup, operation, maintenance, and service of this machine/tool. Save this document, refer to it often, and use it to instruct other operators. Failure to read, understand and follow the instructions in this manual may result in fire or serious personal injury—including amputation, electrocution, or death.

The owner of this machine/tool is solely responsible for its safe use. This

responsibility includes but is not limited to proper installation in a safe environment, personnel training and usage authorization, proper inspection and maintenance, manual availability and comprehension, application of safety devices, sanding/grinding tool integrity, and the usage of personal protective equipment. The manufacturer will not be held liable for injury or property damage from negligence, improper training, machine modifications or misuse.

WARNING!

Some dust created by power sanding, sawing, grinding, contains chemicals known to the State of California to cause cancer, birth defects or other reproductive harm. Some examples of these chemicals are:

- Lead from lead-based paints.
- Crystalline silica from bricks, cement and other masonry products.
- Arsenic and chromium from chemically-treated lumber.

Your risk from these exposures varies, depending on how often you do this type of work. To reduce your exposure to these chemicals: Work in a well ventilated area, and work with approved safety equipment, such as those dust masks that are specially designed to filter out microscopic particles.

	items	Description
1	Name	Gem Faceting Machine
2	Model	KD-8801
3	Parameter	Voltage/Frequency: 110-120VAC/60Hz, Power: 180W, Variable speed: 0-2980rpm
4	Package Size	480x380x330mm
5	G.W.	14.5KG

Manufacturer: Fujian Putian Huajie Electronic Technology Co.,LTD

Address: NO. 30 Shugang Road, Shangtang Village, Dongqiao Town, Xiuyu District, Putian City, Fujian Province

VEVOR[®]

TOUGH TOOLS, HALF PRICE

Technical Support and E-Warranty Certificate

www.vevor.com/support