

VEVOR[®]

HIVE USER MANUAL

Standard Box



NEED HELP? CONTACT US!

Have product questions? Need technical support? Please feel free to contact us:



CustomerService@vevor.com

This is the original instruction, Please read all manual instructions carefully before operating. VEVOR reserves clear interpretation of our user manual. The appearance of the product shall be subject to the product you received. Please forgive us that we won't inform you again if there is any technology or software updates on our product.

INSTALLATION NOTES









NOTES:

1. Try to choose hard ground for installation.
2. Prepare installation tools in advance (Rubber hammer and wood).
3. Carefully read this installation manual and confirm the quantity of accessories according to the list.

MODEL AND PARAMETERS

Model	Standard Box
Product size	562*462*515mm
Cabinet material	Fir wood
Surface treatment	Wax boiling process

COMPONENTS

 <p>A1 240 Coaming I(×2)</p>	 +  <p>B1 240 Coaming 2(×2)</p>	
 <p>A2 170 Coaming I(×2)</p>	 +  <p>B2 170 Coaming 2(×2)</p>	
 <p>C 170/240 Main frame bar 1(×20)</p>	 <p>D 170/240 Main frame bar 2(×20)</p>	 <p>E1 240 Frame bar(×20)</p>

 <p>E2 170 Frame bar(×20)</p>	 <p>F1 240 Foundation sheet(×10)</p>	 <p>F2 170 Foundation sheet(×10)</p>
 <p>G Handle(×2)</p>	 <p>H Screw(×2)</p>	 <p>I Window pane(×2)</p>
 <p>J Self-tapping screw(×4)</p>	 <p>K Small plank(×4)</p>	 <p>L Top Cover(×1)</p>
 <p>M Inner Cover(×1)</p>	 <p>N Bottom Board(×1)</p>	 <p>O Queen Excluder(×1)</p>
 <p>P Entrance Reducer(×1)</p>		

ASSEMBLY

240 BOX

I. Installation of 240 box

Step 1: Take two pieces of A1 and two pieces of B1 respectively, and connect them with a rubber hammer (note that it is not allowed to knock them directly, but put a board or cardboard on them and knock them in evenly).

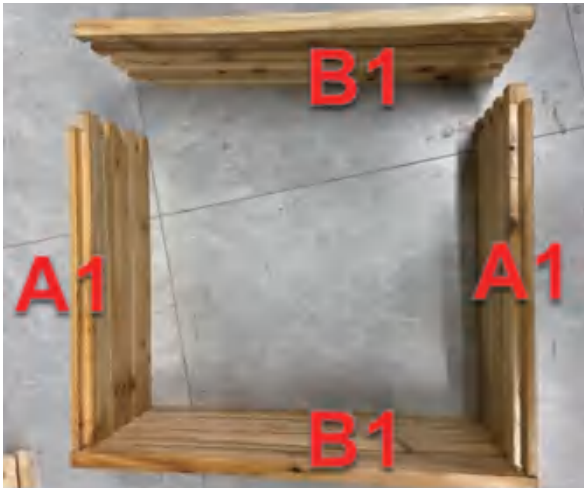

II. Installation of 240 frame

Step 1: Take 2 pieces of E1 and 1 piece of C, insert them into the card slot to connect them, then take 1 piece of F1 and insert it into the slot, and finally take 1 piece of D and insert it into the slot to complete a set of 240 frames.



Step 2: Connect with nails at a/b/c/d 4 positions.

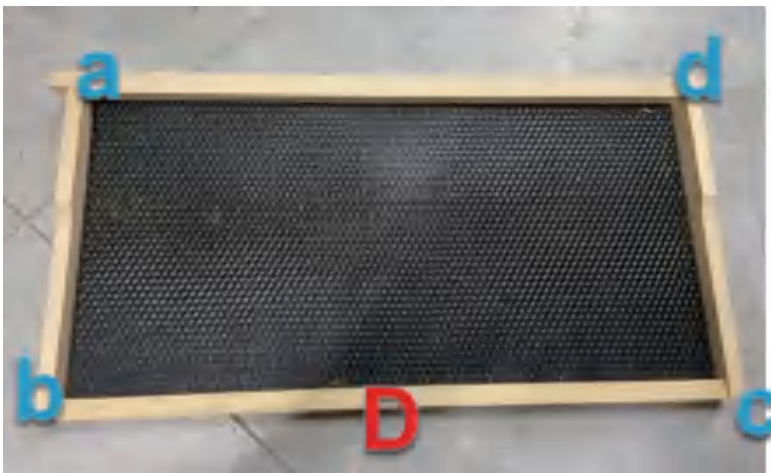

III. Installation of the window

Step 1: Take G, H and I to assemble the cover plate.



Step 2: Take J and K to assemble the window pressing plates on both sides and put 10 sets of foundations and frames into the box.



170 BOX

I. Installation of 170 box

Step 1: Take two pieces of A2 and two pieces of B2 respectively, and connect them with a rubber hammer (note that it is not allowed to knock them directly, but put a board or cardboard on them and knock them in evenly).

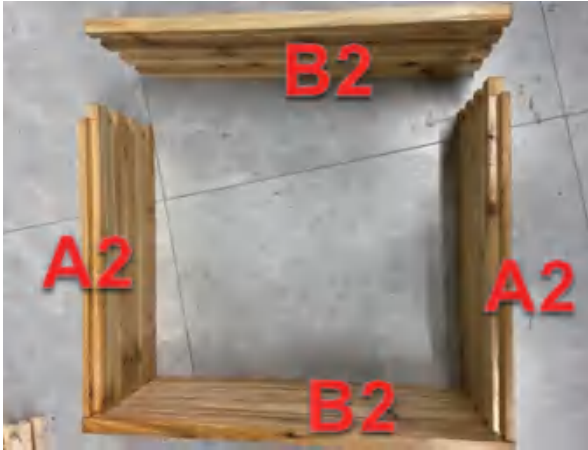

II. Installation of 170 frame

Step 1: Take 2 pieces of E2 and 1 piece of C, insert them into the card slot to connect them, then take 1 piece of F2 and insert it into the slot, and finally take 1 piece of D and insert it into the slot to complete a set of 170 frames.

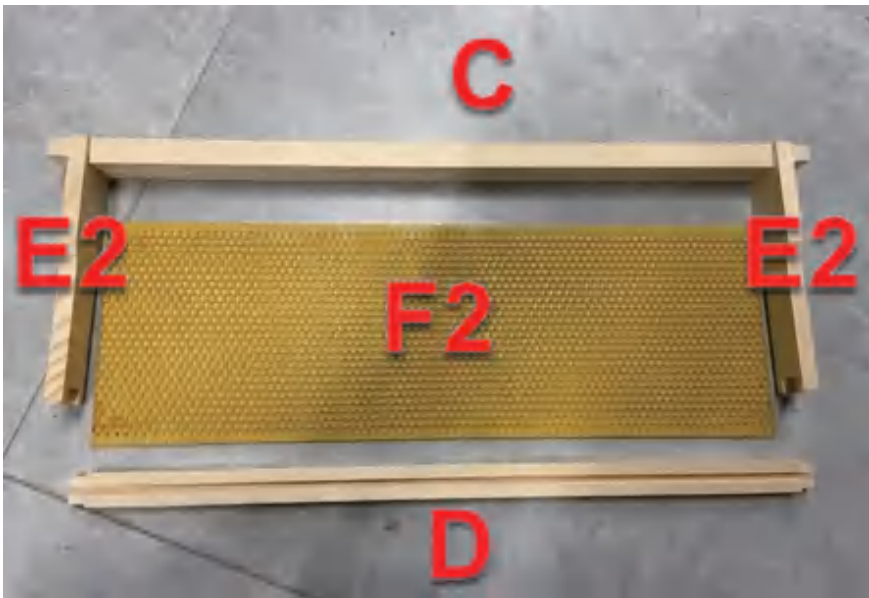

Step 2: Connect with nails at a/b/c/d 4 positions (Please prepare connecting nails by yourself).



III. Installation of the window

Step 1: Take G, H and I to assemble the cover plate.



Step 2: Take J and K to assemble the window pressing plates on both sides and put 10 sets of foundations and frames into the box.



Finally, please assemble according to the following figure:

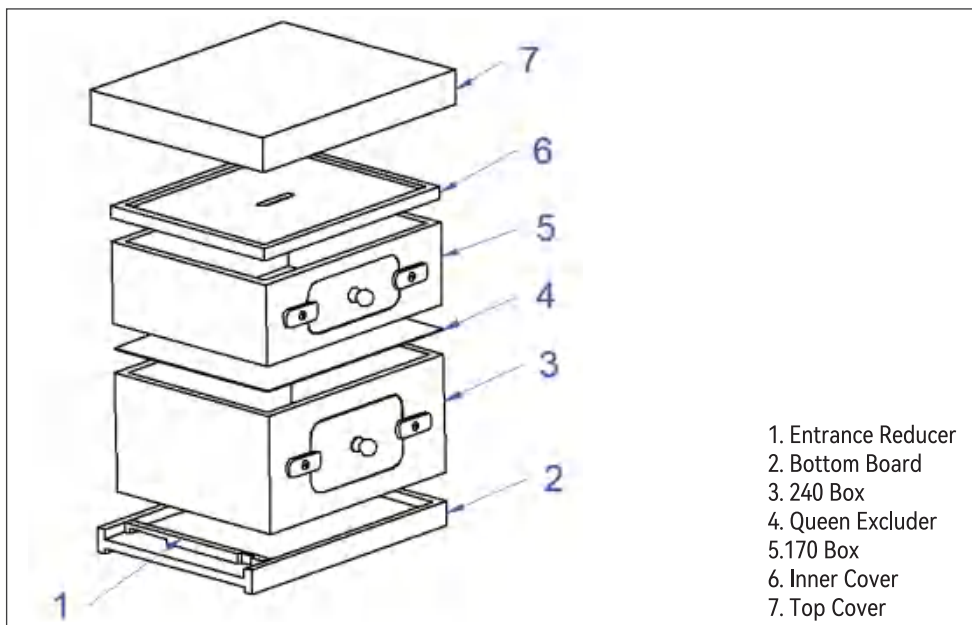

MAINTAIN

1. Please use beeswax regularly for maintenance.
2. Close the bee window in cold, rainy, and windy weather.

Manufacturer: Foshan Juya Environmental Protection Packaging Materials Co., Ltd

Address: Room 301, Building 1, No. 7, North Xinxu Third Road, Xiashi Village, Lunjiao Street, Shunde District, Foshan City, Guangdong Province

UK Importer: FREE MOOD LTD

Address: 2 Holywell Lane, London, England, EC2A 3ET

UK	REP	EUREP UK LTD UNIT 2264, 100 OCK STREET, ABINGDON OXFORDSHIRE ENGLAND OX14 5DH
-----------	------------	---

EC Importer: WAITCHX

Address: 250 bis boulevard Saint-Germain 75007 Paris

EC	REP	EUREP GmbH Unterlettenweg 1a, 85051 Ingolstadt, Germany
-----------	------------	---

Made in China

VEVOR[®]

E-mail: CustomerService@vevor.com