

# Ice Cream Rolls Machine

## Operation Manual

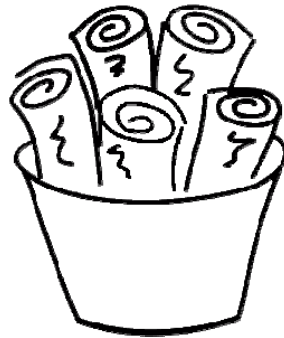

# Content

I Usage of ice Cream Roll Machine .....	1
II Safety Attention.....	1
III Work Condition .....	1
IV Installation .....	2
V Operation Instruction .....	3
VI Precautions .....	4
VII Troubleshooting.....	5
VIII Electric Diagram.....	6
VIII Packing List .....	6

# I Usage of ice Cream Roll Machine

Ice cream roll machine is a foodservice equipment made for ice cream rolls. It can make ice cream rolls with fresh fruit or biscuit. Mix and chop by hand for a while, customs will enjoy the nice and tasty ice cream rolls. Our machines are widely used in cold drinks chain stores, bars, restaurants and other entertainment.

Please check rating label on the machine's side panel closely before operation.

## II Safety Attention

Please read following instruction before use the machine:



Attention:

- ★ Do not run the machine without reading the manual.
- ★ The appliance is not to be used by children or mental capabilities, or lack of experience and knowledge, unless they have been given supervision or instruction.
- ★ Children being supervised not to play with the appliance.
- ★ Children being supervised not to play with the appliance.



WARNING:

- ★ For your safety, please make sure the machine is well grounding.
- ★ If the wire is damaged, it must be changed by maintenance persons.
- ★ Do not insert sticks into the machine when it is running.
- ★ Make sure to turn off power and unplug before maintenance.

## III Work Condition

- (1) Ambient temperature: 5~35°C
- (2) Mix temperature: 10~20°C
- (3) Voltage range: 108~235V/1PH (Please see specs on rating label)
- (4) Hz: 50/60±1Hz (Please see specs on rating label)



**Attention:** Lower ambient temp, proper ventilation, steady voltage, clean conditions and the temp of the mix is as low as possible will make the machine has a higher efficiency, less electricity consumption and long life.

## IV Installation

Many customers summarize a lot of recipe to make different ice cream rolls when using this machine. We suggest you make ice cream rolls mix as follow.

### 1. Recipe

Ingredient (weight ratio): full cream milk power (8%) white sugar (16%) flavor (a little) emulsion stabilizer (0.5%) water (75%) food color (a little)

Attention: In this recipe, the proportion between milk power and sugar is economy type. It cannot be reduced any more, or it will freeze and stick on the pan. If content of sugar is less this proportion or substitute saccharin for sugar. Stabilizer is to improve emulsification and overrun and prevent from freezing.

### 2. Prepare ice cream mix

- 1) All materials as above table
- 2) All materials into container and mix it slowly and equality
- 3) Pouring drink water, mixing it rapidly, assure all the mixer have dissolved (the boiled water is the half of the total water)
- 4) Put into some essence, pigment and water, mixing it when put the powder, make sure all the mixer have dissolved



Attention: The mixer should be mixer equally and dissolved completely. Be sure there is not grain in the mixing. All materials and utensil should meet the Hegelian required. Above two times input water volume should meet the Hegelian required weight.

### 3. Unpack and inspect

- 1) Open the wooden case by screwdriver
- 2) Remove the foam
- 3) Cut off the wrapping tape
- 4) Inspect carefully whether there is defective appearance or not
- 5) Check the accessories with packing list.
- 6) Remove the fixing bolt and fixing feet that are at the bottom of the machine, push the machine, let the front-wheel drive fall to the ground, and then take out the wooden base, let the four wheels grounded. (Directly lift the machine to the ground or on the table if the machine is table type)

### 4. Installation

- 1) Location select
  - a. Place the machine on a level counter that is stable and strong enough to safely support its weight.
  - b. Place the machine in a location that allows adequate space at the back and each side for proper ventilation. Keep 50cm

space from all sides of ventilation. The machine should be shade from the sun and should not be located too close to the units that radiates excessive heat.

2) Power supply

- a. Select the proper power supply according to the voltage and power on the nameplate
- b. Connect the power wire and the power supply, ensuring the machine is properly grounded.



**Caution:**  
For safety, ensure the ground connection is in good condition.  
All the exterior wires and other appliances must confirm with national standard.

5. The Pre-cool of the ice cream mix

In order to let the machine run more efficiently. It is necessary to pre-cool mix. Normally, you can put the mixing on the cool place, let the well-prepared mixing cool by itself .If you have freezer, you can put the mixing into it and pre-cool it to 0~40°C.

## V Operation Instruction

1. Operation panel

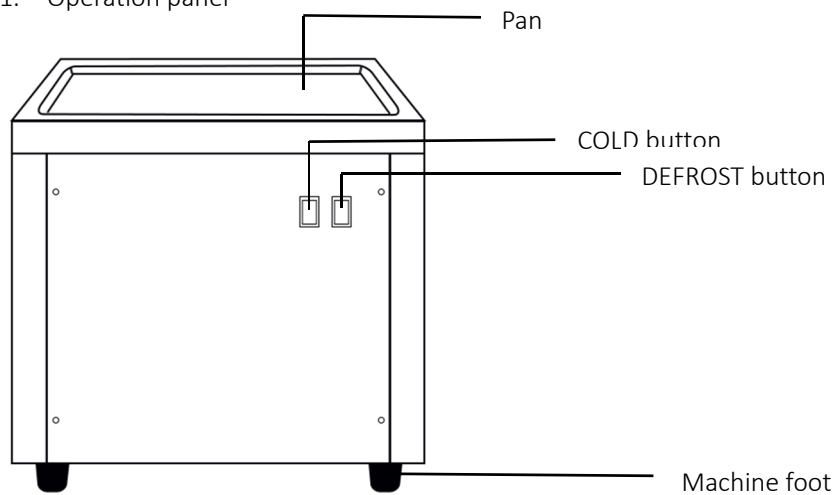

2. Clean up

Before making ice cream rolls, wash the ice pan with clean and wet rag. .

According to the proportion of the weight of the recipe to take a variety of raw materials, pour into a clean container, stir well; then pour into drink water, stir quickly so that the mixture completely dissolved into a thin paste, add appropriate amount of fragrant pigment and drinking water evenly stirred (Note: Twice the amount of water equal to the amount of water in the formula).

3. Making ice cream rolls

- a. Plug in, turn on COLD button, machines starts running and pan starts frosting.
- b. When the ice pan gets cold, pour a certain amount of the prepared mixture onto ice pan. Use two scrapers to chop and mix the mixture.

- c. Spread the chopped ice cream mixture thin and evenly. Roll up the ice cream mixture to ice cream rolls until it is totally frozen.
- d. If the ice cream mixture sticks, push the defrost button for a couple of seconds (about 3- 5 seconds) to release the ice cream from the frozen pan.

\*DEFROST only functions when COLD is on.

\*REMINDER: Please do not shut down and turn on by hand frequently. It may damage the equipment.

Of course you can make smoothie, frozen yogurt barks on this mini ice pan machine by using soda or yogurt and fruit.

Please create your own recipe with so many more ideas!

## **VI Precautions**

- 1) During moving machine, the inclination does not allow more than 45 degrees.
- 2) Power supply voltage requirements of the rated voltage, there must be a reliable grounding; No sharing the same socket with other electrical appliances.
- 3) Out of the wind side should be enough to stay more than 500mm space to ensure that the machine heat.
- 4) When the machine is covered with a lid, avoid pushing the hand into the bucket.
- 5) The machine should be unplugged when doing beater assembly cleaning; after washing with a towel dry, the appearance can be wiped with a wet towel, should not be washed directly with water.
- 6) Ice cream made a good out of the mixing device, check the agitator components are broken, the phenomenon of defects, so as to avoid foreign body eating insecurity caused by insecurity.

## VII Troubleshooting

Problem	Possible cause	Solution
Machine no work	1.Power or voltage unstable	1.Voltage stabilizer
	2.No electricity connected	2.Re-plug in
Frequently shut down	1. Power or voltage unstable	1. Voltage stabilizer
	2.Wind gates blocked	2.500mm at least to wind gates
	3.Environmental temp too hot	3.Change location of machine
	4.Compressor capacity damaged	4.Replace capacity
Too noisy	1.Machine on a bumpy surface	1.Place machine on a flat surface
	2.Foreigh object in fan	2.Remove the object and clean fan areal
	3.Parts on machine loosen	4.Adjust parts and tighten them

## VIII Electric Diagram

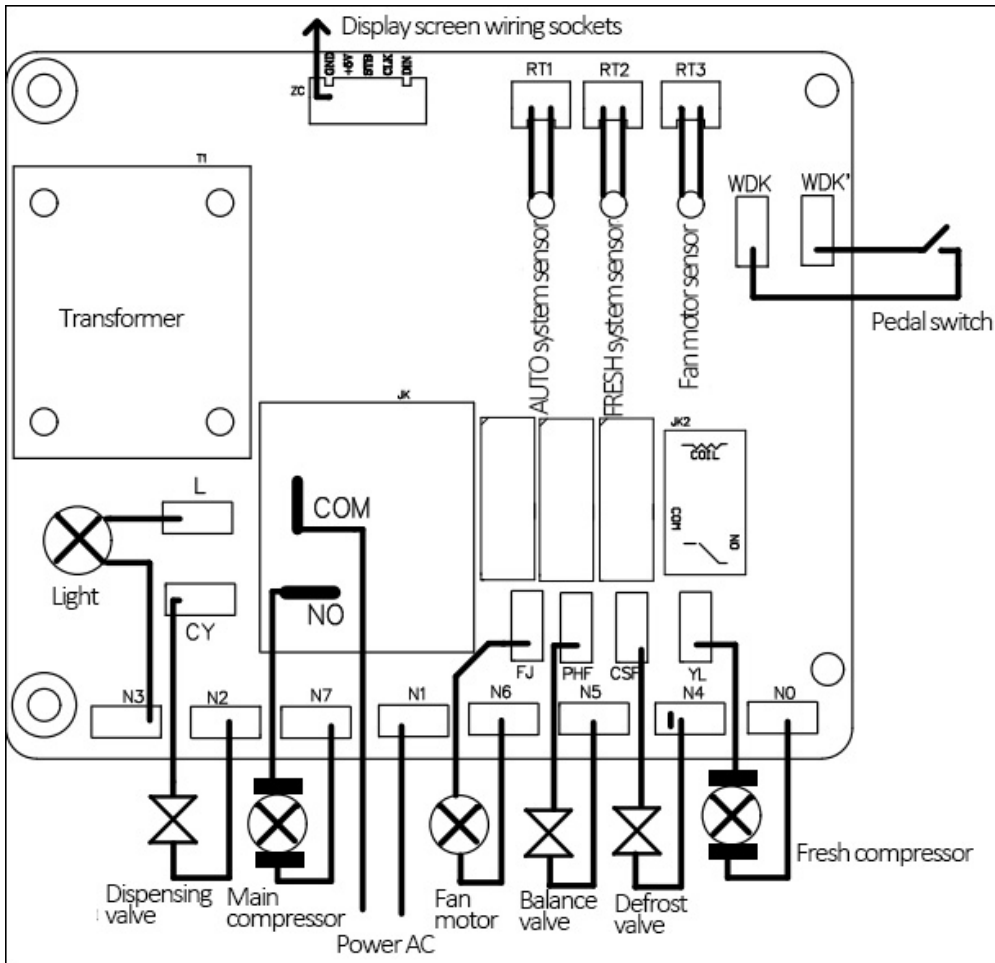

## VIII Packing List

No.	Item	Qty
1	Ice cream rolls machine	1 unit
2	Scraper	2 pcs
3	Operation Manual	1 pc