

BRAKE/CLUTCH BLEEDER SET

OPERATION INSTRUCTION



Specifications

Item	Description
Functions	Remove , and replace fluid from most types and models of vehicle break systems , also removes trapped air.
Working air pressure	10 to 40PSI:consumption :4.5CFM at 30PSI
Air inlet	1/4"-male quick couple
Tank fluid capacity	Tank fluid capacity
Pressure Regulator	Manual control dial , locking
Pressure gauges	0~140PSI,20PSI increments ;within 20PSI increments, marked in increment
Drain tubes	2-12-1/2(L)X0.316(dia.) inches clear polyurethane with rubber bleeder adapter tip
Break fluid filler hose	10feet, 3inches (L)X1/2 inch (dia);reinforced polyurethane with ball valve and quick coupler at one end
Overall dimensions	11(dia.)X8.5(H)X6.5(base dia.) inches Overall height with handle:18 inches
Collection bottles	2-9(H)X4-3/4(L)X2-1/4(W) inches; 0.26 gallon (one quart)
Weight	19.6lbs
Accessories	Master Cylinder adapters kit: 11-domestic and import vehicle in plastic tool box.see parts list at the end of this manual for details

Save this manual

You will need manual for the safety warnings and precautions , assembly instructions, operating and maintenance procedures , parts list and diagram, keep your invoice with this manual .write the invoice number on the inside of the front cover. Keep the manual and invoice in a safe and dry place for future reference.

Safety warnings and precautions

Warning : when using tool ,basic safety precautions should always be followed to reduce the risk of personal injury and damage to equipment. Read all instructions before using this tool!

1. Keep work area clean .cluttered areas invite injuries.
- 2.Observe work area condition. Do not use machines or power tools in damp or wet locations. Don't expose to rain. Keep work area well lighted. Do not use electrically powered tools in the presence of flammable gases or liquids.
- 3.Keep children away. Children must never be allowed in the work area. Do not let them handle machines, tools or extension cords.
- 4.Store idle equipment. When not in use ,tools must be stored in a dry location to inhibit rust. Always lock up tools and keep out of reach of children.
- 5.Use the right tool for the job. Do not attempt to force a small tool or attachment to do the work of a lager industrial tool. There are certain applications for which this tool was designed. It will do the job better and more safety at the rate for which it was intended. Do

not modify this tool and do not use this tool for a purpose for which it was not intended.

6. Dress properly. Do not wear loose clothing or jewelry as they can be caught in moving parts. Protective, electrically non-conductive clothes and non-skid footwear are recommended when working. Wear restrictive hair covering to contain long hair.

7. Use eye and ear protection. Always wear ANSL approved impact safety goggles.

8. Do not overreach. Keep proper footing and balance at times, do not reach over or across running machines.

9. Maintain tools with care. Inspect tool cords and hoses periodically and, if damaged, have them replaced, or repaired by an authorized technician. The handles must be kept clean, dry, and free from oil and grease at all times.

10. Remove adjusting keys and wrenches. Check that keys and adjusting wrenches are removed from the tool or machine work surface before operating.

11. Avoid unintentional starting. Be sure the air pressure is in the off position when not in use and before making hose connections.

12. Stay alert. Watch what you are doing, use common sense. Do not operate any tool when you are tired.

13. Check for damaged parts. Before using any tool, any part that appears damaged should be carefully checked to determine that it will operate properly and perform its intended function. Check for alignment and binding of moving parts; any broken parts or mounting fixtures; and any other condition that may affect proper operation any part that is damaged should be properly repaired or replaced by a qualified technician. Do not use the tool if any control or switch does operate properly.

14. Replacement parts and accessories. When servicing, use only identical replacement parts. Use of any other parts will void the warranty. Only use accessories intended for use with this tool. Approved accessories are available from Harbor Freight Tools.

15. Do not operate tool if under the influence of alcohol or drugs. Read warning labels if taking prescription medicine to determine if your judgment or reflexes are impaired while taking drugs. If there is any doubt, do not operate the tool.

16. Pacemaker safety warning. People with pacemakers should consult their physician(s) before using this produce. Electromagnetic fields in close proximity to a heart pacemaker could cause interference to, or failure of the pacemaker. In addition, people with pacemakers should adhere to the following:

-caution is necessary when near the coil, spark plug cables, or distributor of a running engine. the engine should always be off if adjustments are to be made to the distributor.

17. maintenance. for your safety, service and maintenance should be performed regularly by a qualified technician.

Note: performance of this tool may vary depending on variations in air pressure and compressor capability.

Brake fluid exchanger safety precautions

Caution: this equipment is designed to be operated by qualified and trained personnel. It should only be operated after reading and understanding the safety warnings and operating procedures in this instruction manual and vehicle's service manual.

1. Wear safety goggles.
2. Do not smoke near this equipment.
3. Use in a well ventilated area.
4. When leaks are found in the equipment or hoses, immediately turn the air pressure off and repair the leaks.
5. Immediately clean up any fluid spills or leaks.
6. Do not exceed the recommended operating air pressure. This could damage equipment. See specifications on page 2.
7. Do not use any cleaning compounds in this system.
8. Keep an empty plastic bucket nearby in case of fires
9. Keep a type ABC fire extinguisher nearby in case of leaks.
10. Prior to using the brake fluid exchanger, make sur to read and understand all warnings, safety precautions, and instructions as outlined in the vehicle manufacturer's service manual. Every vehicle has specific brake bleeding requirements. It is beyond the scope of this manual to

properly describe the correct procedure for each vehicle.

11. Prior to using the Break Fluid Exchanger, make sure to place the vehicle's transmission in "PARK"(if automatic) or "NEUTRAL"(if manual). then, set the emergency parking brake and block the tires with chocks.]

12. Use the Break Fluid Exchanger only with brake fluid. Do not attempt to use the tool to siphon any other liquids. Contamination of break fluid and possible break system failure may result.

13. follow guidelines for proper brake fluid disposal. Used brake fluid should be properly disposed of or recycled. many states require recycling. Contact your local solid/liquid waster authority for information on recycling. do not reuse old brake fluid.

14. do not use pressurized air to blow off brake dust. Only use brake parts cleaner to clean dust off of the brake calipers.

15. be alert for hot brake components and other hot vehicle components to avoid accidental burns.

16. some brake pads contain asbestos. Asbestosis, a chronic lung inflammation, can result from prolonged inhalation of asbestos particles. Accordingly, wear appropriate respiratory devices and proper protective clothing when working near any break pads.

17. always keep brake fluid from contacting the vehicle's paint finish. Brake fluid will damage the paint finish on vehicles.

Warning: the warnings, cautions, and instructions discussed in this instruction manual cannot cover all possible conditions and situations that may occur, it must be under-stood by the operator that common sense and caution are factors which cannot be built into this product, but must be supplied by the operator.

Unpacking

When unpacking, check to make sure the following parts are included. If any parts are missing or broken, please call Cannon Tools at the number on the cover of this manual as soon as possible.

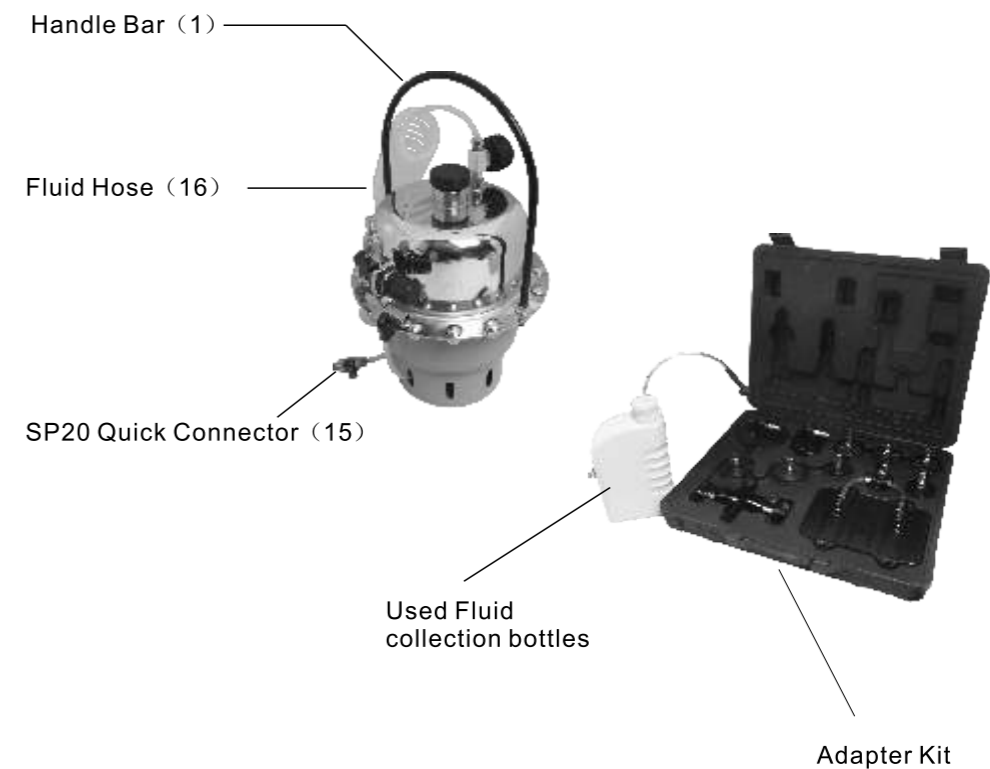

Operation

Preparation

1. Lase vehicle on a hoist or on secure vehicle stands in a well ventilated area.
2. set vehicle emergency brake and turn engine off.
3. remove the wheels and locate the drain connection on the brake cylinders. Refer to the vehicle manufacturer's maintenance manual for their location.
4. turn on the air compressor (not supplied) and place its hose next to the Break Fluid Exchanger(the air compressor should have a moisture filter installed on it. See illustration on the top of page 6.)

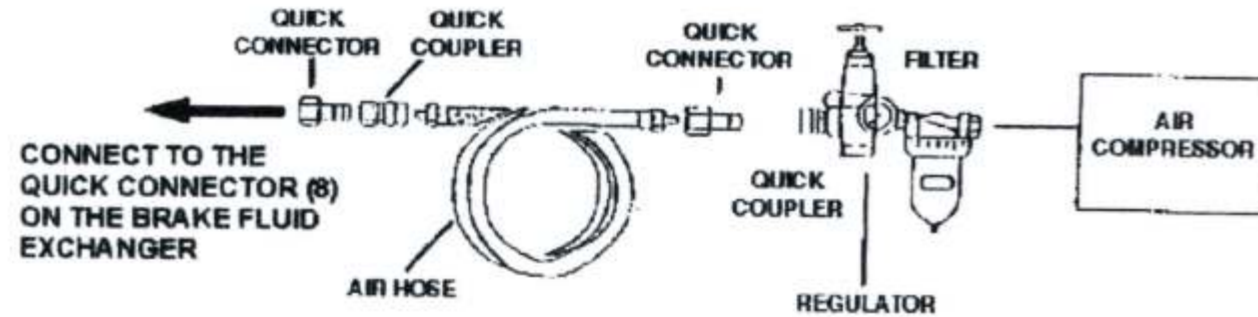

Controls and Indicators



Bleeding brakes and adding new fluid

Warning: the vehicle engine must never be started in a closed garage, or any other sealed structure. Carbon monoxide is produced during operation and is deadly in a closed environment. Early signs of carbon monoxide poisoning resemble the flu, with headaches, dizziness, or nausea..if you have any of these signs get fresh air immediately.

1. Place the Brake Fluid Exchanger near the vehicle and remove the Tank Cap(2)
2. Open and secure the engine hood and find the Master Cylinder.
3. Remove the Master Cylinder Lid.
4. Open the Adapter Kit and find the Adapter Lid that looks like, and best fits, the Master Cylinder.

Refer to the Adapter Kit Parts List at the end of this manual. The temporary Adapter Lid should have the from of the Master Cylinder Lid with the addition of a connector inlet for the Fluid Hose(16).In some instances, a universal Lid (E1,F1,or F2) may need to be used where other Adapters will not fit. Use the mounting loop cables and hardware provided with the

Adapter to secure the universal Lid.

5. Secure the Adapter Lid to the Master Cylinder.

6. Unscrew and remove the Tank Cap(2), then pour in the appropriate amount of new brake fluid. Refer to the vehicle manufacturer's service manual for the correct amount and type of fluid. Screw in the Tank Cap(2) tightly.

7. Insert the Fluid Hose(16) Quick Connector(15) onto the temporary Master Cylinder Adapter Lid. Make sure that's Ball valve(9) is in the closed position (sideways to the direction of the Fluid Hose).

8. Remove the Drain Screws from the rear brake cylinder, and insert clear rubber tube(not supplied) in to the drain holes. Press fit the rubber connector of the Used Fluid Bottles into the other end of the clear rubber tube

Note: The Used Fluid Bottles can be connected directly to the brake cylinders drain, but you will not be able to see the color of the fluid the bottles(darker is old, lighter is new).

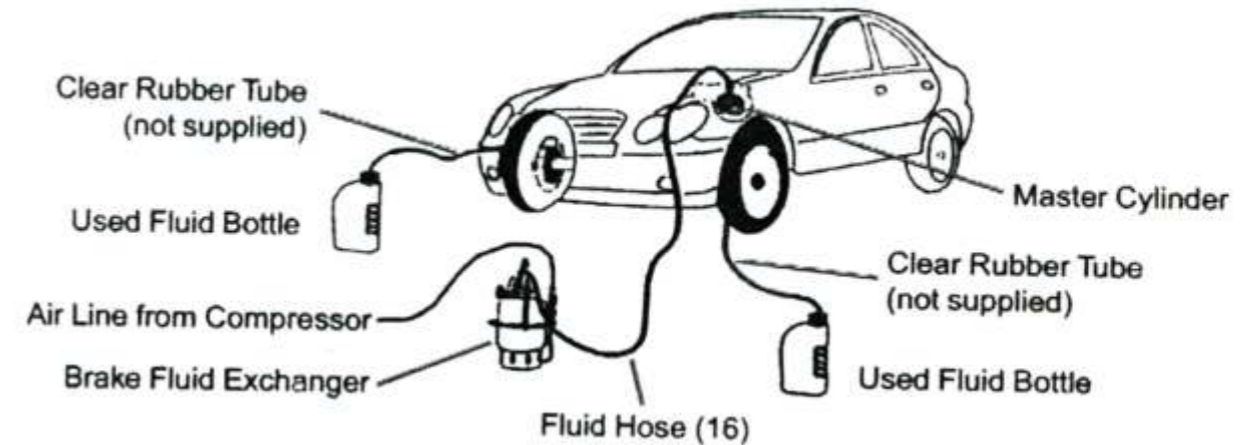

9. Connect the air line hose(not supplied) to the Air Hose Quick Connector (8) on the Brake Fluid Exchanger.

10. Set the Air Connector Ball Valve(9) to the ON(vertrical) position.

11. Pull out on the Pressure Adjust Valve(10) knob, and while viewing the Pressure Gauge(19), turn the knob to adjust the Tank pressure to between 20 to 40 PSI

Caution: Never exceed 40 PSI or damage may occur to equipment and connection hoses.

12. Slowing open (in line with hose) the Fluid Hose (16)Ball Valve (9) on top of the Master Cylinder.

This begins the process of forcing the new fluid in , and while oil fluid out and into the Used Fluid Bottles. Check for leaks at all connection Points. If leaks and continue.

13. During the fluid transfer, press in quickly on the brake pedal in the vehicle, and release slowly do this a few times.

14. When the Used Fluid Bottles are full , or the fluid color has changed from dark to light as seen through

15. Remover the Used Fluid Bottles or Clear Rubber Tubes connected to the brake cylinder and return screws to the drain holes.

16. Empty the Used Fluid Bottles into a fluid recycle tank, or in other bottles for proper disposal.

17. Repeat steps 8 through 15 the front brake cylinders.

18. When the fluid transfer of the front brake cylinders is complete, turn the Ball Valve(9) on the Master Cylinder to the Off(sindeways) position, and remove the Fluid Hose(16) from the Master Cylinder lid,

Adding New Fluid to Vehicles with ABS Brake Systems

1. Follow all the previous steps ,with these exceptions.

2. Remove the drain screw for only on the brake cylinder at a time, and drain that brake cylinder.

3. Place the vehicle transmission in Park, and start the engine during this process. When adding new fluid is complete, turn the engine off.

4. Remove the Used fluid bottle or Clear Rubber Tube connected to that brake cylinder and

return screw to the drain hole.
 5.Repeat for each brake cylinder individually.

Steps When Finished Bleeding Brakes and Adding New Fluid

1. Replace the original Master Cylinder lid.
- 2.Remove the air input line from Air hose Quick Connector(8)on the Tank.
- 3.Open the Air release Ball Valve(9) on the Tank, and pull on the Air Release Safety Valve(12) to depressurize the Tank.
- 4.Empty the Used Fluid Bottles into a fluid recycle tank, or in other bottles for proper disposal.

WARNING: Before driving the vehicle, depress the brake pedal repeatedly until the brake pedal feels firm. Check the brake calipers for leaks. Then, test the brakes thoroughly at slow speed before operating the vehicle under normal conditions.

Maintenance

Caution: Before performing any maintenance on the Brake Fluid Exchanger, verify that the Brake Fluid Exchanger is depressurized.

1. Clean up any brake fluid oil that may have spilled.
- 2.Wipe down the Brake Fluid Exchanger components with a cloth.
- 3.Store the unit n a clean and dry location.

Brake fluid Ecchanger Parts List

1	Handle Bar	1	10	Connector	2
2	Cap, Tank	1	11	Valve, Safety, Air Release	1
3	Tank , Upper Half	1	12	Connector	1
4	Rubber Membrane	1	13	Tube	1
5	Tank, lower Half	1	14	Connector, Quick Fluid	1
6	Connector, PL802L	1	15	Hose, Fluid	1
7	Connector, Quick	1	16	Coupler	1
8	Valve,Ball, 1/4"	3	17	Gauge, Pressure	1
9	Valve, Pressure Adjust	1	18	Coupler, Pressure Gauge	1

NOTE: Some parts are listen and shown for illustration purposes only and are not available individually as replacement parts.

Brake Fluid Exchanger Assembly Drawing

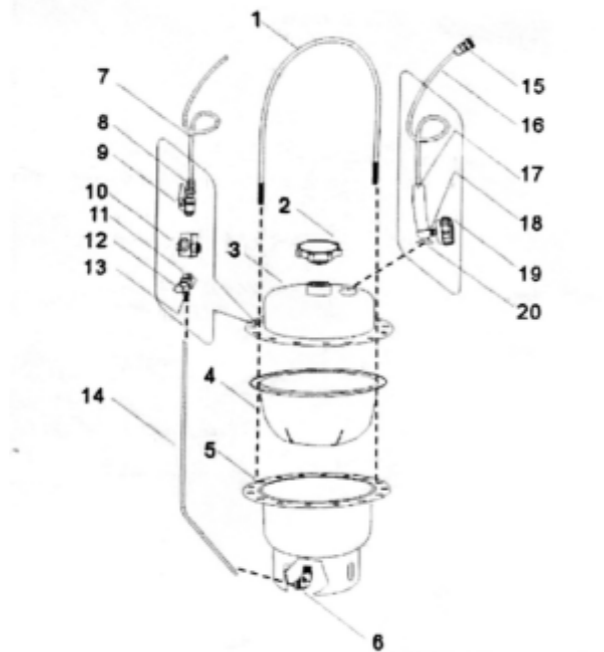

Adapter Kit Parts List

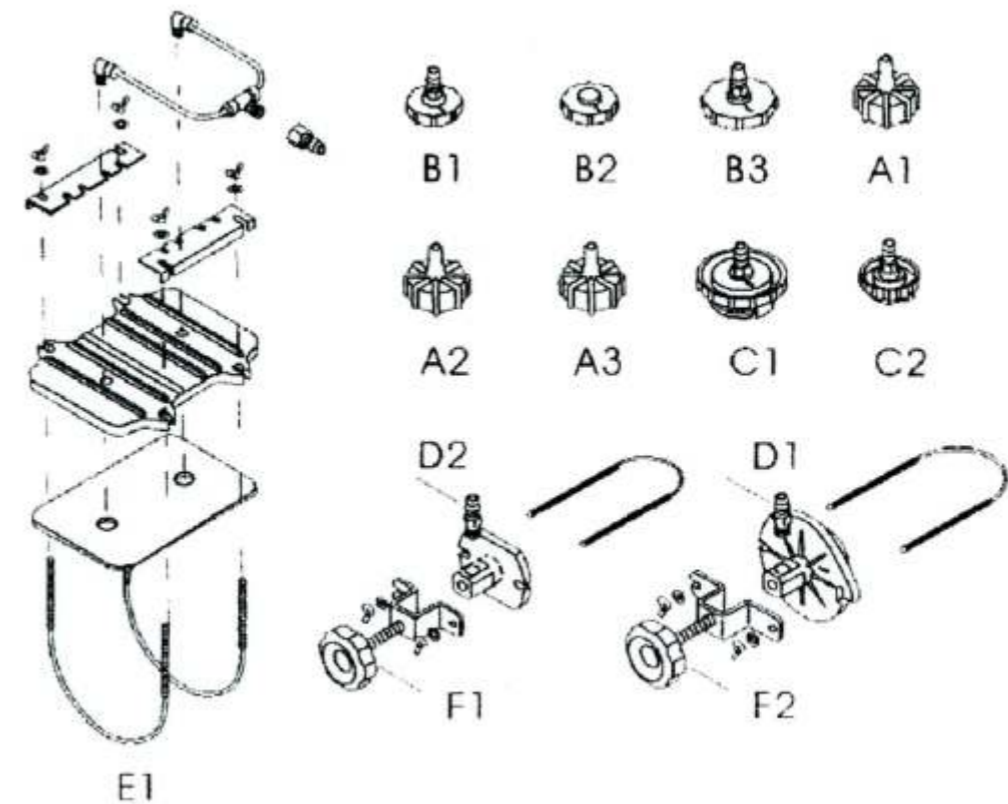

PLEASE READ THE FOLLOWING CAREFULLY

THE MANUFACTURER AND/OR DISTRIBUTOR HAS PROVIDED THE PARTS DIAGRAM IN THIS MANUAL AS A REFERENCE TOOL ONLY. NEITHER THE MANUFACTURER NOR DISTRIBUTOR MAKES ANY REPRESENTATION OR WARRANTY OF ANY KIND TO THE BUYER THAT HE OR SHE IS QUALIFIED TO MAKE ANY REPAIRS TO THE PRODUCT OR THAT HE OR SHE IS QUALIFIED TO REPLACE ANY PARTS OF THE PRODUCT. IN FACT, THE MANUFACTURER AND/OR DISTRIBUTOR EXPRESSLY STATES THAT ALL REPAIRS AND PARTS REPLACEMENTS SHOULD BE UNDERTAKEN BY CERTIFIED AND LICENSED TECHNICIANS AND NOT BY THE BUYER. THE BUYER ASSUMES ALL RISK AND LIABILITY ARISING OUT OF HIS OR HER REPAIRS TO THE ORIGINAL PRODUCT OR REPLACEMENT PARTS THERETO, OR ARISING OUT OF HIS OR HER INSTALLATION OF REPLACEMENT PARTS THERETO