

**VEVOR<sup>®</sup>**

**SUBMERSIBLE SUMP PUMP  
OWNER'S MANUAL**



# VEVOR<sup>®</sup>

## SUBMERSIBLE SUMP PUMP PSSP10003

PSSP10003

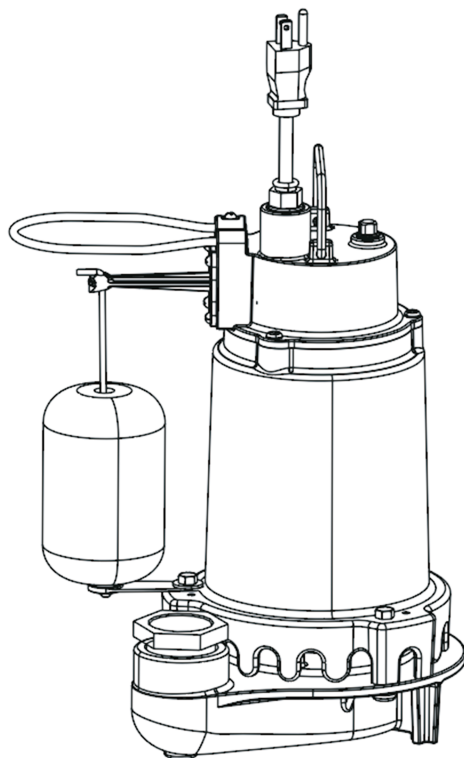

**NEED HELP? CONTACT US!**

Have product questions? Need technical support? Please feel free to contact us:

 [CustomerService@vevor.com](mailto:CustomerService@vevor.com)

## Performance

Model	HP	GPH of Water @ Total Feet Of Lift						Max. Lift
		0 ft.	5 ft.	10 ft.	15 ft.	20 ft.	25 ft.	
PSSP10003	1	5600	5220	4720	4320	3660	2520	32ft

## Safety Instructions

1. Do not pump flammable or explosive liquids such as oil, gasoline, kerosene, ethanol, etc. Do not use in the presence of flammable or explosive vapors. Using this pump with or near flammable liquids can cause an explosion or fire, resulting in property damage, serious personal injury, and/or death.

2. ALWAYS disconnect the power to the pump before servicing.

3. Do not touch the motor housing during operation. The motor is designed to operate at high temperatures. Do not disassemble the motor housing.

4. Do not handle the pump or pump motor with wet hands or when standing on a wet or damp surface, or in water before disconnect the power.

5. Release all pressure and drain all water from the system before servicing any component.

6. Secure the discharge line before starting the pump. An unsecured discharge line will whip, possibly causing personal injury, and/or property damage.

7. Extension cords may not deliver sufficient voltage to the pump motor. Extension cords present a life threatening safety hazard if the insulation becomes damaged or the connection ends fall into water. The use of an extension cord to power this pump is not permitted.

8. Wear safety goggles at all times when working with pumps.

9. This unit is designed only for use on 115 volts (single phase), 60 Hz, and is equipped with an approved 3-conductor cord and 3-prong grounded plug. Do not remove the ground pin under any circumstances. The 3-prong plug must be directly inserted into a properly installed and grounded 3-prong, grounding-type receptacle. Do not use this pump with a 2-prong wall outlet. Replace the 2-prong outlet with a properly grounded 3-prong receptacle (a GFCI outlet) installed in accordance with the National Electrical Code and local codes and ordinances. All wiring should be performed by a qualified electrician.

10. Protect the electrical cord from sharp objects, hot surfaces, oil, and chemicals. Avoid kinking the cord. Do not use damaged or worn cords.

11. Failure to comply with the instruction and designed operation of this unit may void the warranty. ATTEMPTING TO USE A DAMAGED PUMP can result in property damage, serious personal injury, and/or death.

12. Ensure that the electrical circuit to the pump is protected by a 15 Amp fuse or circuit breaker.

13. Do not lift the pump by the power cord.

14. Know the pump and its applications, limitations, and potential hazards.



15. Secure the pump to a solid base. This will aid in keeping the pump in a vertical orientation. This is critical in keeping the pump operating at maximum efficiency. It will also help prevent the pump from clogging resulting in premature failure.

16. Periodically inspect the pump and system components to ensure the pump suction screen is free of mud, sand, and debris. Disconnect the pump from the power supply before inspecting.

17. Follow all local electrical and safety codes, along with the National Electrical Code (NEC). In addition, all Occupational Safety and Health Administration (OSHA) guidelines must be followed.

18. The motor of this pump has a thermal protector that will trip if the motor becomes too hot. The protector will reset itself once the motor cools down and an acceptable temperature has been reached. The pump may start unexpectedly if it is plugged in.

19. Ensure the electrical power source is adequate for the requirements of the pump.



20. This pump is made of high-strength, corrosion-resistant materials. It will provide trouble-free service for a long time when properly installed, maintained, and used. However, inadequate electrical power to the pump, dirt, or debris may cause the pump to fail. Please carefully read the manual and follow the instructions regarding common pump problems and remedies.



## Pre-Installation

### Application

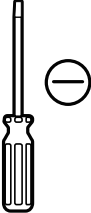
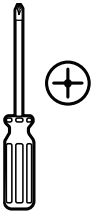
- This submersible sump pump is designed for home sump applications. Use this pump only for pumping water.
- This unit is not designed as a waterfall or fountain pump, or for applications involving salt water or brine! Use with waterfalls, fountains, salt water or brine will void warranty.
- Do not use where water recirculates.
- Not designed for use as a swimming pool drainer.



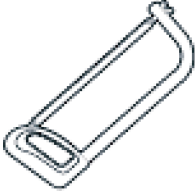

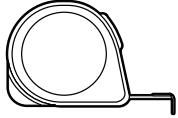

### Tools Required

			
Flathead Screwdriver	Phillips Screwdriver	Channel Locks	Pipe wrench

			
Hacksaw	Cable Ties	Safety goggles	Tape Measure

### Materials Required (Not Included)

**NOTE:** Parts shown below not to scale.

		
Threaded Adapter (Pipe to Pump)	1-1/4" or 1-1/2" ABS or PVC Pipe	Thread Tape
		
1-1/4" or 1-1/2" check valve	ABS or PVC Cement (to match the pipe)	1-1/4" or 1-1/2" 90° Elbow

### Specifications

<b>Power supply</b>	115V, 60 HZ., 15 Amp Circuit
<b>Liquid temp. range</b>	32°F to 95°F (0°- 35°C)
<b>Discharge size</b>	1-1/2 in. FNPT or 1-1/4 in. FNPT (with adaptor)
<b>Sump basin</b>	Min. 10 in. (254 mm) diameter, 14 in. (356 mm) depth

**NOTE:** Do not reduce size of discharge pipe or hose below 1-1/4 in. diameter. If discharge is too small, pump will overheat and fail prematurely. This pump is designed for use in a residential sump only. Only pump water with this pump.

# Installation

**1.** Install the pump in sump pit with minimum diameter of 10 in. (254 mm) for models equipped with vertical switches and 14 in. (356 mm) for tethered float switch models. The sump depth should be 14 in. (356 mm) for vertically switched models and 18 in. (457 mm) for tethered models. Construct the sump pit of tile, concrete, steel or plastic. Check local codes for approved materials and for proper installation.

**2.** Install the pump in a pit so that the switch operating mechanism has maximum possible clearance.

**3.** The pump should not be installed on clay, earth or sand surfaces. Clean the sump pit of small stones and gravel which could clog the pump. Keep the pump inlet screen clear.

**NOTE:** Do not use ordinary pipe joint compound on plastic pipe. Pipe joint compound can attack plastics.

**4.** Install discharge plumbing. Insert rigid plastic pipe into the slip of male adapter. Screw pipe into the pump hand tight plus 1-1/2 turns.

**CAUTION:** Risk of flooding. Can cause personal injury and/or property damage. If a flexible discharge hose is used, make sure the pump is secured in the sump to prevent movement. Failure to secure the pump may allow pump movement, switch interference and prevent the pump from starting or stopping.

**5.** To reduce motor noise and vibrations, a short length of rubber hose (1-7/8 in. (47.6 mm) I.D., e.g. radiator hose) can be connected into the discharge line near the pump using suitable clamps.

**6.** Install an in-line check valve or an in-pump check valve to prevent flow backwards through the pump when the pump shuts off.

**NOTE:** If your check valve is not equipped with an air bleed hole to prevent air locking the pump, drill a 1/8" (3.2mm) hole in discharge pipe about 1"-2" (2.5 -5.1cm) above connector. The hole must be in the sump.

**7. Power Supply:** Pump is designed for 115 V, 60 Hz, operation and requires a minimum 15 amp individual branch circuit. Plug the power plug into a 115V GFCI power outlet.

**WARNING:** Risk of electric shock. Can shock, burn or kill. Pump should always be electrically grounded to a suitable electrical ground such as a grounded water pipe or a properly grounded metallic raceway, or ground wire system. Do not cut off the round ground pin.

**8.** If the pump discharge line is exposed to outside subfreezing atmosphere, a portion of line exposed must be installed so any water remaining in the pipe will drain to the outfall by gravity. Failure to do this can cause water trapped in the discharge to freeze which could result in damage to the pump.

**9.** After the piping and check valve have been installed, the unit is ready for operation. Check the pump operation by filling the sump with water and observing pump operation through one complete cycle.

**CAUTION:** Risk of flooding. Can cause personal injury and/or property damage. Failure to make this operational check may lead to improper operation, premature failure, and flooding.

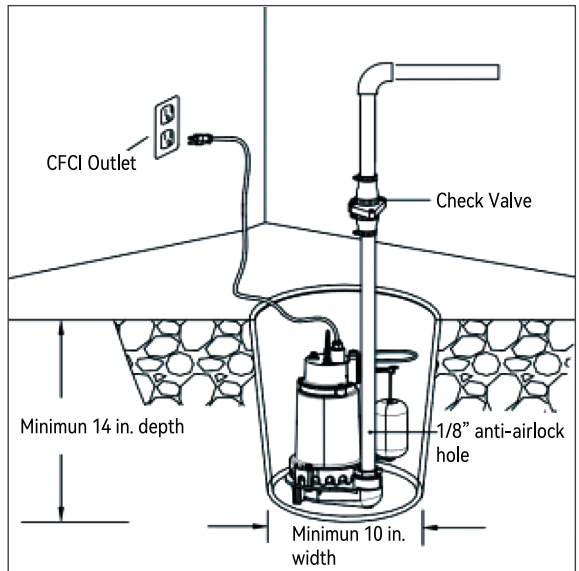

## Operation

**WARNING:** Risk of electrical shock. Can shock, burn or kill. Do not handle a pump or pump motor with wet hands or when standing on a wet or damp surface, or in water.

**WARNING:** Risk of fire and explosion. Can cause severe injury, property damage or death. Do not use in explosive atmospheres. Pump water only with this pump.

1. The shaft seal depends on water for lubrication. Do not operate the pump unless it is submerged in water as the seal may be damaged if allowed to run dry.

2. The motor is equipped with an automatic reset thermal protector. If temperature in the motor should rise unduly, the switch will cut off all power before damage can be done to the motor. When the motor has cooled sufficiently, the switch will reset automatically and restart the motor. If the protector trips repeatedly, the pump should be removed and checked. Low voltage, long extension cords, clogged impeller, very low head or lift, or a plugged or frozen discharge pipe, etc., could cause the protector to trip.

3. The pump will not remove all water.

**WARNING:** Risk of electric shock. Can shock, burn or kill. Before attempting to check why the unit has stopped operating, disconnect power from the unit.

## Care And Cleaning

**CAUTION:** Always use the handle to lift pump. Never use the power cord to lift the pump. To avoid skin burns, unplug the pump and allow time for it to cool after periods of extended use.

Do	Do Not
<ul style="list-style-type: none"><li>•When the power is disconnected, inspect the pump suction screen and remove all debris, then plug the pump back into the grounded (GFCI) outlet.</li></ul>	<ul style="list-style-type: none"><li>•Do not disassemble the motor housing. This motor has NO repairable internal parts, and disassembly may cause leakage or dangerous electrical wiring issues.</li><li>•Do not lift up the pump by the power cord.</li></ul>

### To clean a pump clogged with debris:

- Unplug the pump from electrical power.
- Unscrew the stainless screws (1), and remove the volute (7).
- Remove the nut (6) and gasket (5) from the shaft (2), then take off the impeller (4) from shaft (2).
- Remove debris from around the shaft (2) and the impeller (4).
- Reassemble the pump.

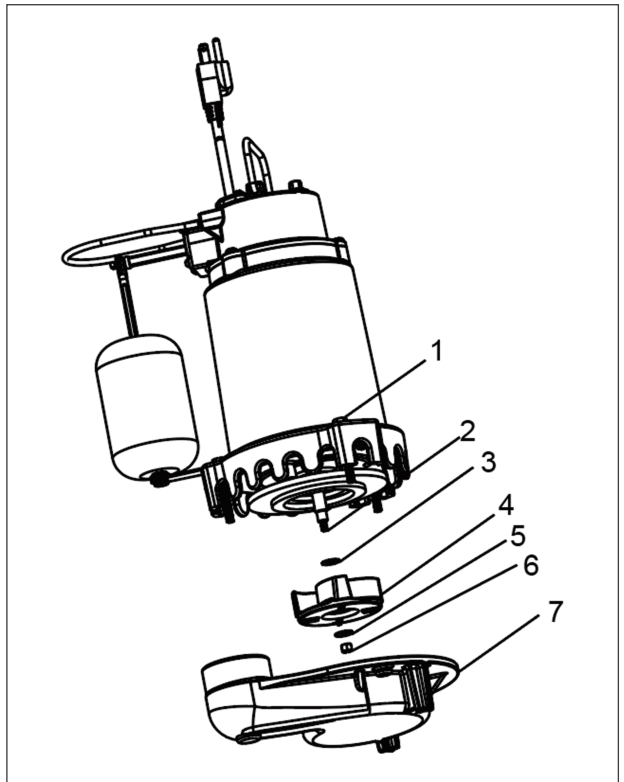

## Troubleshooting

Problem	Possible Cause	Corrective action
Pump won't start or run.	<ol style="list-style-type: none"> <li>1.No power.</li> <li>2.Clogged impeller.</li> <li>3.Defective motor.</li> <li>4.Float is obstructed.</li> </ol>	<ol style="list-style-type: none"> <li>1.Reset GFCI switch/Reset the breaker/Secure the plug/Clean the plug prongs.</li> <li>2.Remove the debris around the impeller.</li> <li>3.Replaced the pump.</li> <li>4.Remove the obstruction.</li> </ol>
Pump operates but delivers little or no water.	<ol style="list-style-type: none"> <li>1.Debris is caught in impeller.</li> <li>2.Impeller is broken.</li> </ol>	<ol style="list-style-type: none"> <li>1.Clean out the impeller.</li> <li>2.Replace the impeller.</li> </ol>
Pump starts and stops too often.	<ol style="list-style-type: none"> <li>1.Back flow of water from pipe.</li> </ol>	<ol style="list-style-type: none"> <li>1.Install or replace the check valve.</li> </ol>
Pump won't shut off.	<ol style="list-style-type: none"> <li>1.Defective float switch.</li> <li>2.Restricted discharge.</li> <li>3.Float obstructed.</li> </ol>	<ol style="list-style-type: none"> <li>1.Replace the float switch.</li> <li>2.Remove the pump and clean the pump and piping.</li> <li>3.Remove the obstruction.</li> </ol>

**E-mail:** CustomerService@vevor.com

**Manufacturer:** GP Enterprises Co., Ltd.

**ADD:** No.27 Qianzhu Road,Wuzhong Economic Development Distrct,Suzhou City,Jiangsu 215104, CHINA

**Made in China**



**VEVOR<sup>®</sup>**

E-mail: [CustomerService@vevor.com](mailto:CustomerService@vevor.com)